

APPLICABLE MODELS BELOW:	
SKU #	DESCRIPTION
SE-0018	1% CO2
SE-0118	10% CO2
SE-0117	1% CO2, FR 2Hz
SE-0127*	1% CO2, ASCII

*Includes connectors shown in phantom lines below

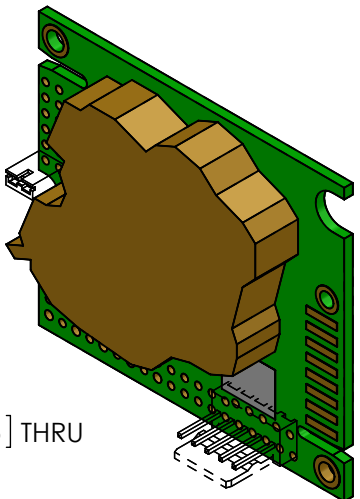

- NOTES:**
- DO NOT SCALE FROM THIS DRAWING
 - PRIMARY UNITS IN INCHES (IN), DUAL UNITS IN MILLIMETERS (MM).
 - BOARD ELECTRONIC COMPONENTS, SENSOR AND SURFACE DETAILS FOR ILLUSTRATION PURPOSES ONLY.

131 Business Center
Building A-3
Ormond Beach, FL

CO2METER.COM
CO2 MEASUREMENT SPECIALISTS

Toll free: 877.678.4259
Fax: 866.422.2356
www.co2meter.com

Title: **K30 CO2 SENSOR**

APPROVALS	DATE	SIZE	PART NO.	REV
DRAWN JMC	11/19/2013	A	VDD-0019	-
CHECKED MV	12/13/2013	SCALE 1:1	THIRD ANGLE PROJECTION	SHEET SHEET 1 OF 2