

# FIGARO FG-010 CO2 SENSOR MANUAL & COMMUNICATION SPECIFICATIONS

The **FG-010** CO2 module uses a non-dispersive infrared (NDIR) sensor principle and compact optics to achieve excellent performance characteristics, including high accuracy and low power consumption. Two detector elements inside the module make absolute

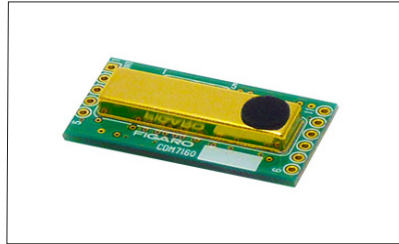

measurement possible. Every module is individually calibrated and is provided with both a UART and I2C digital interface. The FG-010 module is designed for simple integration into a user's products. It can be used in a wide range of applications such as ventilation controls for the improvement of energy savings and to assure a good indoor climate.

Page

<i>Basic Information and Specifications</i>	
Features.....	2
Applications.....	2
Basic Principle and Structure.....	2
Operating Conditions and Specifications.....	2
Absolute Maximum Ratings.....	2
Dimensions.....	3
Functions.....	3
Pin Configuration/Functions.....	3
Installation and Soldering Conditions.....	4
<i>Reliability</i>	
Long Term Stability.....	5
Corrosion Test.....	5
Dust Test.....	5
Temperature Cycle Test.....	5
High/Low Temperature Test.....	5
<i>Communication</i>	
UART Communication.....	6
I2C Communication.....	8
<i>Housing Design</i> .....	10
<i>Packaging</i> .....	11
<i>Maintenance</i> .....	11
<i>Handling Precautions</i> .....	11
<i>Frequently Asked Questions</i> .....	12
<i>Part 2: Communication Specifications</i> .....	13

**IMPORTANT NOTE:** OPERATING CONDITIONS IN WHICH FIGARO SENSORS ARE USED WILL VARY WITH EACH CUSTOMER'S SPECIFIC APPLICATIONS. FIGARO STRONGLY RECOMMENDS CONSULTING OUR TECHNICAL STAFF BEFORE DEPLOYING FIGARO SENSORS IN YOUR APPLICATION AND, IN PARTICULAR, WHEN CUSTOMER'S TARGET GASES ARE NOT LISTED HEREIN. FIGARO CANNOT ASSUME ANY RESPONSIBILITY FOR ANY USE OF ITS SENSORS IN A PRODUCT OR APPLICATION FOR WHICH THE SENSOR HAS NOT BEEN SPECIFICALLY TESTED BY FIGARO.

## 1. Basic Information and Specifications

### 1-1 Features

- \* Small size
- \* Low power
- \* High accuracy
- \* Absolute measurement via dual sensors

### 1-2 Applications:

- \* Indoor air quality control
- \* Fresh air ventilators
- \* Air conditioners
- \* Automatic fans and window openers

### 1-3 Basic principle and structure

Fig. 1 shows the basic principle of measuring absolute values. Fig. 2 shows the basic structure of the module's optics.

This sensor is a single light source, dual wavelength system. The sensor employs two detectors with different optical filters in front of each detector. One detector measures the intensity of infrared light passing through the optical filter, transmitting only the infrared wavelength region absorbed by CO<sub>2</sub> (CO<sub>2</sub> absorption wavelength). The other detector measures the intensity of infrared light passing through the optical filter, transmitting only an infrared wavelength (3.8μm) not absorbed by CO<sub>2</sub> (i.e. a reference wavelength), and is thus unaffected by the constant presence of CO<sub>2</sub>.

Measuring absolute values of CO<sub>2</sub> concentration by FG-010 is achieved by the module's microprocessor calculating CO<sub>2</sub> concentration from the difference between light intensity transmitted at the CO<sub>2</sub> absorption wavelength and at the reference wavelength.

The single light source, dual wavelength system employed by the FG-010 measures light intensities at two different wavelengths after separation by two optical filters, thus compensating drift due to accumulated dust and contamination. This ensures long term stability, minimum maintenance, and cost-effectiveness.

### 1-4 Operating conditions & specifications (refer to Table 1)

### 1-5 Absolute maximum ratings (refer to Table 2)

Products using FG-010 should be designed so that these maximum ratings are *never* exceeded.

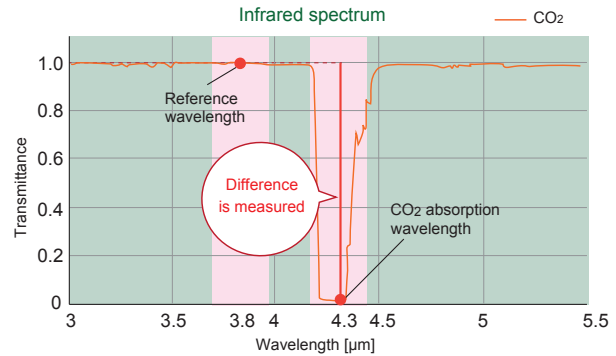

Fig. 1 - Basic principle for measuring absolute values

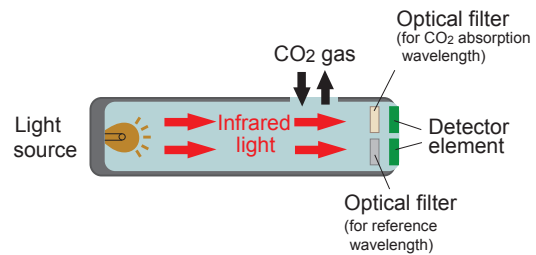

Fig. 2 - Basic structure of FG-010 optics

Product name	Carbon dioxide (CO <sub>2</sub> ) sensor module
Model No.	FG-010
Detection range	300~5,000ppm CO <sub>2</sub>
Operating principle	Non-dispersive infrared (NDIR)
Power supply	4.75~5.25V DC
Current consumption	60mA peak, 10mA avg.
Accuracy (Note 1)	±(50ppm+3% of reading) in the range of 300~5,000ppm CO <sub>2</sub>
Pressure dependency	approx 1% of reading / kPa
Response time (T <sub>90</sub> )	2 min. (diffusion)
Operating conditions	0~50°C/0~85%RH (no condensation)
Storage conditions	-30~70°C/0~85%RH (no condensation)
Communication port	UART/ I2C (gas conc. output 0~10,000ppm)
Measurement interval	2 sec.
PWM output (1kHz)	0~100% duty cycle for 0~5,000ppm, CMOS output
Alarm output	CMOS output: High>1,000ppm Low<900ppm
Dimensions	32 x 17 x 7.5 (mm)
Weight	approx. 3g

Table 1 - Specifications of FG-010

Note 1: Represents accuracy at the time of factory test. For long term accuracy, please refer to Fig. 5 - Long term stability of FG-010.

### 1-6 Dimensions (Fig. 3)

#### 1-7 Functions

FG-010 has the following 4 major functions:

##### 1-7-1 CO<sub>2</sub> concentration output

FG-010 has two CO<sub>2</sub> concentration outputs. One is PWM output (please refer to Sec. 1-8-3 - Pin No.4), the other is digital output through the communication port (please refer to Sec. 3 - Communication).

##### 1-7-2 Alarm signal output

FG-010 has an alarm signal output. Please refer to Sec 1-8-3. Pin No.3 (Alarm) for further information about this signal.

##### 1-7-3 Calibration function

FG-010 has two calibration functions. One is air adjustment, the other is zero adjustment. With air adjustment, CO<sub>2</sub> concentration output is set at 400ppm, assuming the sensor is exposed to 400ppm CO<sub>2</sub> (normal CO<sub>2</sub> levels in clean air are approx. 400ppm). With zero adjustment, CO<sub>2</sub> concentration output is set at 0ppm, assuming the sensor is exposed to 0ppm CO<sub>2</sub>. For further details, please refer to Sec 1-8-6. Pin No.7 (CAL).

##### 1-7-4 Atmospheric pressure and altitude compensation

The factory default setting of FG-010 for atmospheric pressure and altitude is fixed at 1013.25 hPa and 0m. Since FG-010 has pressure and altitude dependency, compensation for atmospheric pressure and altitude is needed to obtain high accuracy under different pressures/altitudes. To compensate, please refer to the document *FG-010 Communication Specifications*.

### 1-8 Pin configurations and functions (Table 3)

#### 1-8-1 Pin No.1 (VDD)

Since a voltage regulator is included in the sensor, input voltage variation within the range of 4.75~5.25V does not affect output voltage of the sensor.

#### 1-8-2 Pin No.3 (ALARM)

The factory settings of the alarm threshold are 1000ppm for alarm trigger and 900ppm for alarm reset. The thresholds are user-changable. Please refer to the document *FG-010 Communication Specifications*.

Pin connection

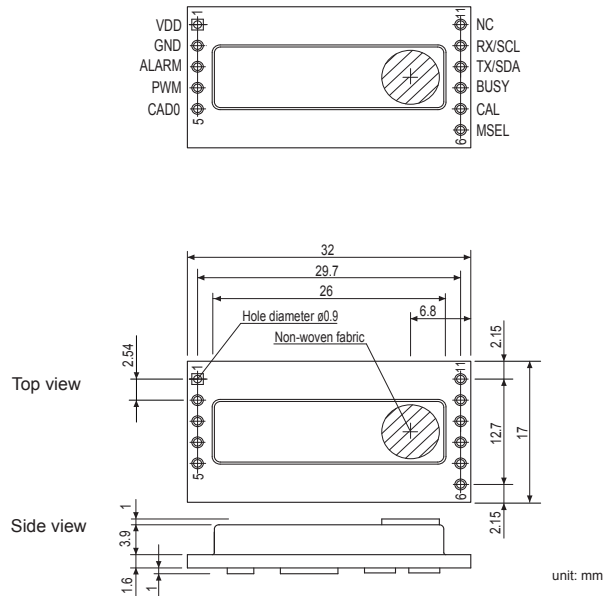

Fig. 3 - Dimensions of FG-010

Item	Min.	Max.	u/m
Ambient temperature	-40	85	°C
Input voltage	-0.3	5.5	V
Maximum input voltage (MSEL in, CAD in, CAL in, Rx/SCL)	-0.3	VDD+0.2 and 5.5	V
Maximum output current (Alarm, PWM, Busy, Tx/SDA)	-	50	mA

Table 2 - Absolute maximum ratings for FG-010

Pin No	Name	Description
1	VDD	Input voltage
2	GND	Common ground
3	ALARM	Alarm output
4	PWM	PWM output
5	CAD0	I2C slave address selection input (internal pull up)
6	MSEL	Communication mode signal input I2C/UART (internal pull up)
7	CAL	Air/zero adjustment input (internal pull up)
8	BUSY	BUSY signal output
9	Tx/SDA	UART Tx output/ I2C SDA input/output
10	Rx/SCL	UART Rx input/ I2C SCL input
11	NC	not connected

Table 3 - Pin configurations and functions of FG-010

### 1-8-3 Pin No.4 (PWM)

A pulse of 1kHz that corresponds to 0~5,000ppm CO<sub>2</sub> is output from Pin No.4. A PWM signal can be easily converted to analog voltage. Please refer to Fig.4 for an example circuit.

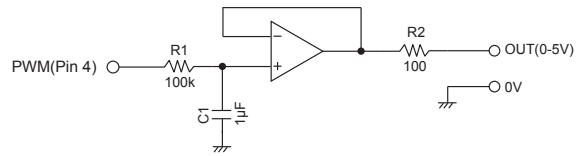

Fig. 4 - PWM signal conversion circuit

### 1-8-4 Pin No.5 (CAD0)

This port is for the selection of the least significant bit of the I2C slave address. By assigning High or Low to each slave, a maximum of 2 units of FG-010 can be connected to one I2C bus. Since this pin is internally pulled up, if this port is not connected, High is input.

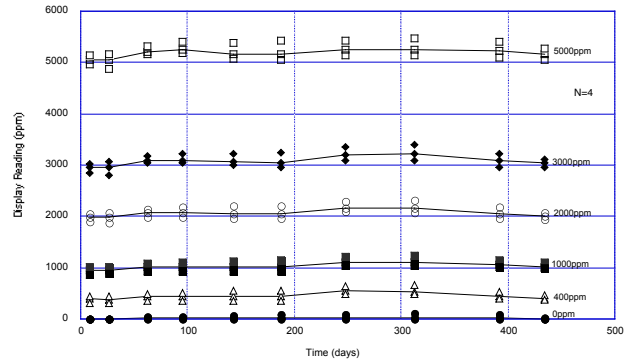

Fig. 5 - Long term stability of FG-010

### 1-8-6 Pin No.7 (CAL)

When Low voltage is applied to this port, calibration mode is activated. During normal operation (i.e. when calibration is not being performed), please connect to High or do not connect (open). (This pin is internally pulled up.)

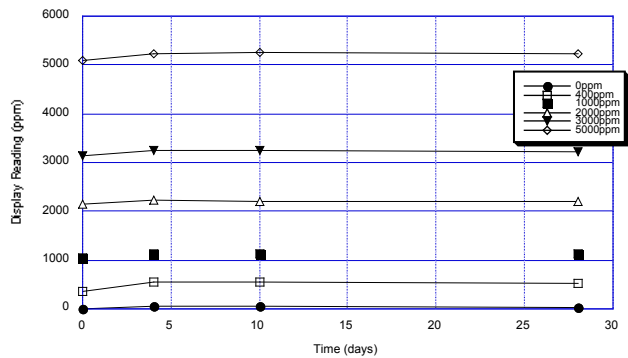

Fig. 6-1 - Durability of FG-010 against H<sub>2</sub>S

When this pin is connected to Low for 4~10 sec., air adjustment is carried out assuming 400ppm exposure to the sensor.

When connected to Low for 12 sec. or longer, zero adjustment is carried out assuming 0ppm exposure to the sensor.

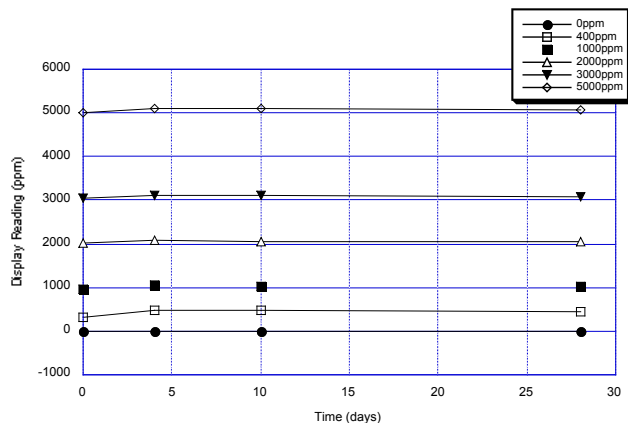

Fig. 6-2 - Durability of FG-010 against SO<sub>2</sub>

### 1-8-7 Pin No.8 (BUSY)

The sensor may not communicate for a short period (about 0.3 sec.) due to the internal processing. During the BUSY state, High signal is output. For more detail, please refer to the document *FG-010 Communication Specifications*.

### 1-8-8 Pin No. 9 (Tx/SDA)

This port works as a Tx port for UART communication and as a SDA (data) port for I2C communication.

### 1-8-9 Pin No. 10 (Rx/SCL)

This port works as an Rx port for UART communication and as a SCL (clock) port for I2C communication.

### 1-9 Installation and soldering conditions

FG-010 can be mounted on a mother printed circuit board by soldering the 0.9mm $\phi$  terminal holes of the sensor to pin strips of a 2.54mm pitch.

## 2. Reliability

### 2-1 Long term stability

Fig. 5 shows the long term stability of the sensor. The Y-axis shows CO<sub>2</sub> concentration output at various concentrations of CO<sub>2</sub>. The CO<sub>2</sub> concentration output is stable during the test period.

### 2-2 Corrosion test

The influence of corrosive gases on the sensor was evaluated. Test samples were stored at 40°C/82%RH. Under this condition, two different tests were carried out:

- 1) exposure to 3ppm H<sub>2</sub>S for 28 days
- 2) exposure to 10ppm SO<sub>2</sub> for 28 days

After gas exposure was concluded, CO<sub>2</sub> concentration output was measured.

Fig. 6-1 and Fig. 6-2 show the durability test results for H<sub>2</sub>S and SO<sub>2</sub> respectively. The test results demonstrate that there is no significant influence on the sensor from this corrosive gas exposure test.

### 2-3 Dust test

Durability against dust exposure was tested. Five different types of dust as specified by JIS Z 8901 were dropped onto the sensor continuously for 15 minutes under conditions of 22°C/41%RH. Fig. 7 shows CO<sub>2</sub> concentration output before and after the dust test. This demonstrates that there is no significant influence from this dust exposure test on sensor performance.

### 2-4 Temperature cycle test

Durability to temperature cycling was tested. Test samples were exposed to 500 cycles of -30°C/30 minutes and 70°C/30 minutes. The test results shown in Fig. 8 demonstrate that there is no significant influence on the sensor from the extreme conditions of this temperature cycle.

### 2-5 High/Low temperature test

Fig.9-1 shows the test result when the samples were operated at 60°C with a maximum input voltage 5.25V. Before measuring the CO<sub>2</sub> concentration output, sensors were conditioned at room temperature for 1 hour. The test result demonstrates that there is no significant influence from high temperature.

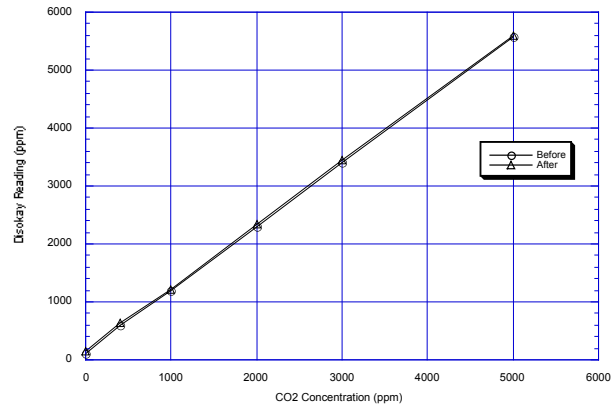

Fig. 7 - Durability of FG-010 against dust

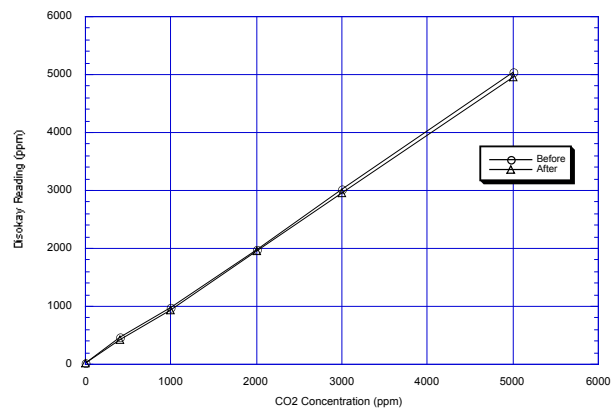

Fig. 8 - Durability of FG-010 to temperature cycling

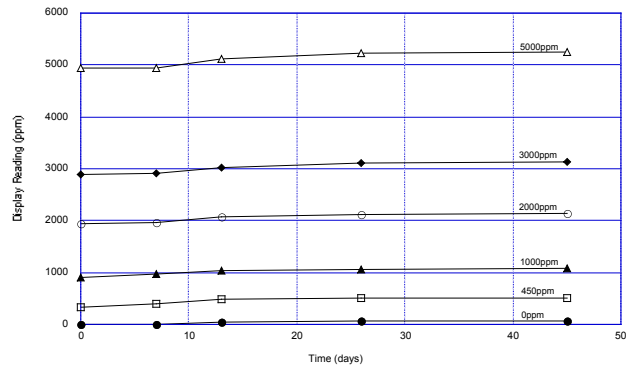

Fig. 9-1 - Durability of FG-010 to high temperature (60°C)

Fig.9-2 shows the test result when the samples were operated at -10°C with a minimum input voltage 4.75V. Before measuring the CO2 concentration output, sensors were conditioned at room temperature for 1 hour. The test result demonstrates that there is no significant influence from low temperature.

### 3. Communication

The sensor is provided with both UART and I2C digital interfaces. There are two operating modes:

- 1) continuous operating mode
- 2) power down mode.

To change register value in I2C communication, it is necessary to write the register value after switching to power down mode.

#### 3-1 UART communication

##### 3-1-1 Connection

Please connect the system (Master) and FG-010 (Slave) as shown in Fig.10.

##### 3-1-2 Basic operation

When FG-010 is reset with the MSEL pin being set to High, the sensor starts operation in the UART communication mode. When the sensor is unable to communicate during internal processing, the BUSY terminal will output a High signal. The external controller (Master) should monitor the terminal output to check for the status of communication.

##### 3-1-2-1 Communication parameters (Table 4)

##### 3-1-2-2 Protocol

The communication protocol of FG-010 is similar to but not fully compatible with Modbus protocol. With Modbus protocol, the master always sends

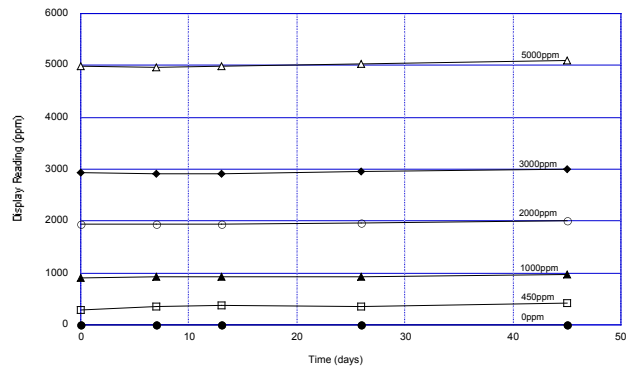

Fig. 9-2 - Durability of FG-010 to low temperature (-10°C)

Communication speed	9600bps
Parity	No
Start bit	1 bit
Stop bit	1 bit
Bit length	8
Flow control	No

Table 4- UART communication parameters

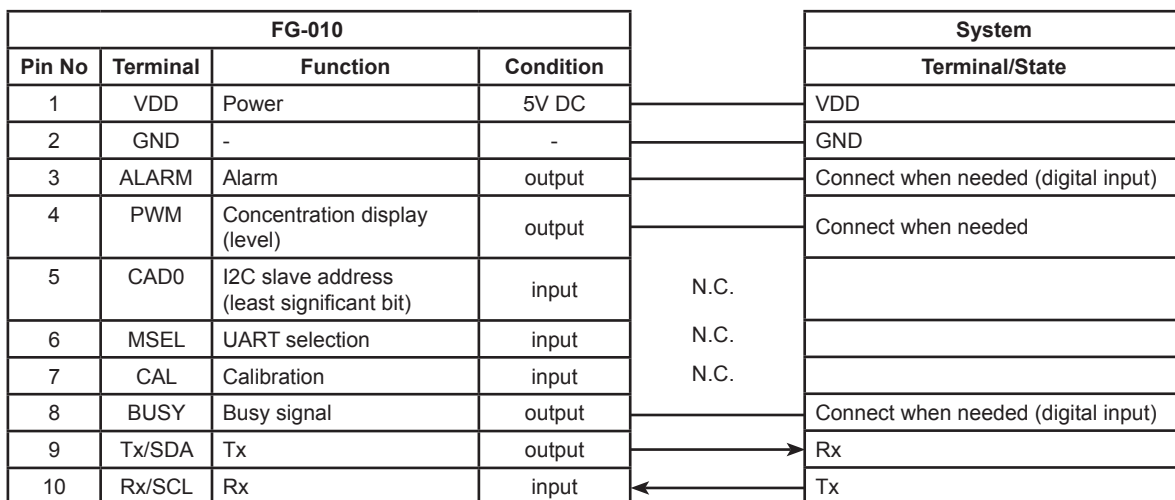

Fig. 10 - UART connections



messages and the slave responds to them. The external controller serves as the master device (Master) and the FG-010 serves as the slave device (Slave).

The transmission procedure is as follows:

- 1) The master sends a command message to the slave.
- 2) The slave checks if the device address in the received message matches its own address.

When the addresses match, the slave performs processing according to the function code and sends back a response message. When the addresses do not match, the slave discards the received message and waits for the next message.

**Note:**

Please insert a space corresponding to 3.5 bytes or more before and after messages. Please do not include space characters of 1.5 bytes or more between bytes within a message.

**3-1-2-3 Structure of message (Table 5)**

The command message from Master and the response message from Slave consist of four parts: Device address, Function code, Data section, and Error check code. They are sent in this order.

There are two kinds of function commands:

- 1) similar to Modbus (Modbus common command)
- 2) a specially designed command for FG-010 (FG-010 unique command). (see Table 6)

**Notes:**

- 1) For both kinds of commands, the Master always sends messages and the Slave responds to them.
- 2) The FG-010 unique command can access the CO<sub>2</sub> concentration readout-only area the same as the Modbus common command. In addition, FG-010 unique command can access the registered memory area which is shown in Sec. 3-2-5.

No.	Name	Byte
1	Device address <sup>*1</sup>	1
2	Function code	1
3	Data section	2~17
4	Error check code <sup>*2</sup>	2

<sup>\*1</sup> Please fix "FEH" for device address

<sup>\*2</sup> Please calculate error check code using CRC-16 method. Please refer to document *FG-010 Communication Specifications*

Table 5 - UART message structure

Command Group	Function
Modbus common command	CO <sub>2</sub> concentration readout User calibration
FG-010 unique command	CO <sub>2</sub> concentration readout Alarm threshold change Altitude pressure compensation User calibration

Table 6 - UART function commands

**Message from Master**

	Device code	Function code	Data part (1)	Data part (2)	Data part (3)	Data part (4)	Error check (1)	Error check (2)
CO <sub>2</sub> concentration readout	FE	04	00	03	00	01	D5	C5

Readout start address      Number of readout words

**Response from Slave**

	Device code	Function code	Data part (1)	Data part (2)	Data part (3)	Error check (1)	Error check (2)
CO <sub>2</sub> concentration readout	FE	04	02	06	5B	EF	7F

Number of readout bytes      CO<sub>2</sub> concentration (hexidecimal number)

Table 7 - Modbus common command for CO<sub>2</sub> concentration readout (example)

**Message from Master**

	Device code	Function code	Data part (1)	Data part (2)	Data part (3)	Error check (1)	Error check (2)
CO <sub>2</sub> concentration readout	FE	44	00	08	02	9F	25

**Response from Slave**

	Device code	Function code	Data part (1)	Data part (2)	Data part (3)	Error check (1)	Error check (2)
CO <sub>2</sub> concentration readout	FE	44	02	06	59	7B	7E

Number of readout bytes      CO<sub>2</sub> concentration (0659H=1625ppm)

Table 8 - FG-010 unique command for CO<sub>2</sub> concentration readout (example)

**3-1-2-4 Message example**

3-1-2-4-1 Example of Modbus common command for CO<sub>2</sub> concentration readout (Table 7)

3-1-2-4-2 Example of FG-010 unique command for CO<sub>2</sub> concentration readout (Table 8)

**Note:**

Please refer to the document *FG-010 Communication Specifications* for how to make an error check code (CRC-16 calculation method).

**3-2 I2C communication**

**3-2-1 Connection**

Please connect the system (Master) and FG-010 (Slave) as shown in Fig. 11.

When Low voltage is applied to the MSEL pin, FG-010 starts operation in I2C communication mode.

**3-2-2 Basic operation**

Operating sequence from the Master side

1. Transmit "Start Condition" to Slave
2. Transmit Slave address
3. Acknowledge (Ack.) is transmitted from Slave (FG-010) back to the Master
4. Transmit Register address to Slave
5. Acknowledge (Ack.) is transmitted from Slave (FG-010) back to Master
6. Repeat steps 4 and 5
7. Send "Stop Condition" to Slave

**4-2-3 Address and register**

Address and register consist of 1 byte (=8 bits). Data with 2 bytes or longer will be transmitted from the highest-order bit (big endian).

**3-2-3-1 Bit configuration of Slave address (1 byte) (Table9)**

Within one byte, the highest 7 bits are used for the



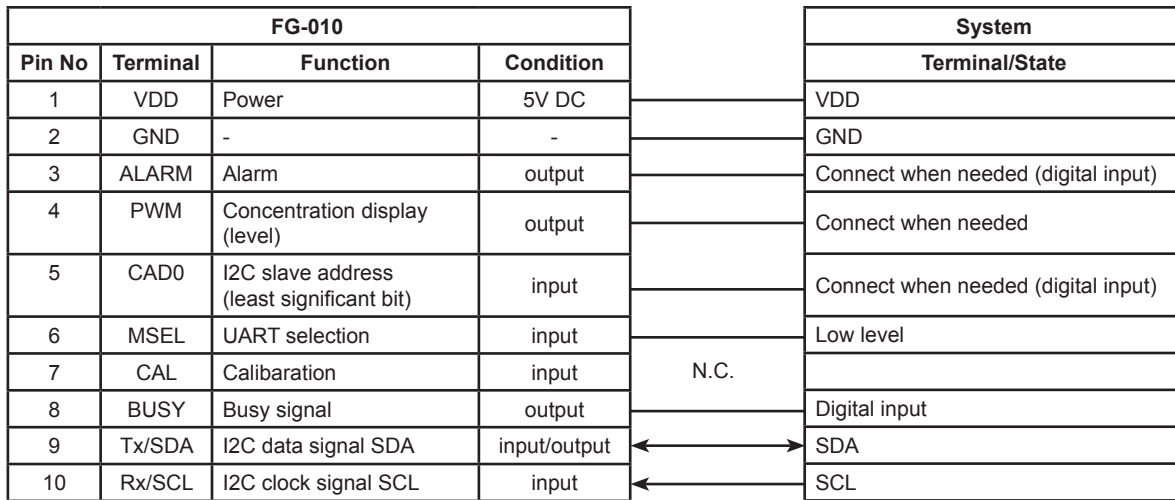

Fig. 11 - I2C connections

slave address, and the least significant bit is used to select Read or Write.

b7~b1: Slave address

where:

b1 corresponds to H/L of CAD0 port (5 pin)

b1 = 0 for CAD0 = Low,

b1 = 1 for CAD0 = High

b0=1 for Read

b0=0 for Write

examples:

Slave address to Write with CAD0=Low

11010000

Slave address to Read with CAD0=High

11010011

3-2-3-2 Bit configuration of Register address (1 byte) (Table 10)

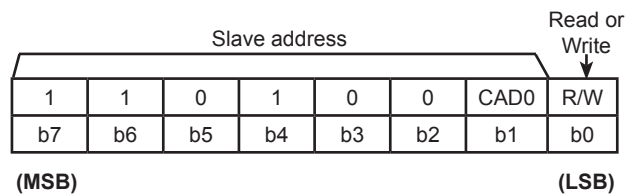

Table 9 - Bit configuration of slave address

A7	A6	A5	A4	A3	A2	A1	A0
b7	b6	b5	b4	b3	b2	b1	b0
(MSB)				(LSB)			

Table 10 - Bit configuration of register address (1byte)

D7	D6	D5	D4	D3	D2	D1	D0
b7	b6	b5	b4	b3	b2	b1	b0
(MSB)				(LSB)			

Table 11 - Bit configuration of data (1byte)

### 3-2-4-1 Write command

Fig.12 shows the data transfer sequence for the Write command. In this sequence, "06H" is written at register address "01H" for setting continuous operating mode. When CAD0=Low, the Slave address is 110100.

For details about the Start bit, Stop bit, ACK, and NACK, please refer to the document *FG-010 Communication Specifications*.

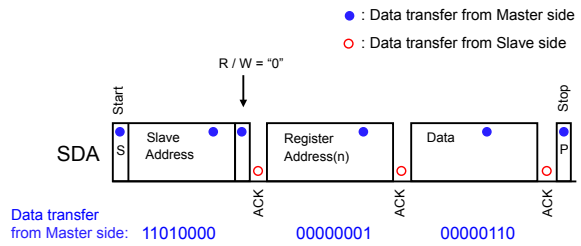

Fig. 12 - Data transfer sequence for Write command

### 3-2-4-2 Read command

There are two Read commands:

- 1) current address read command
- 2) random read command.

Fig.13 shows the random read command. The data transmission sequence shows how CO<sub>2</sub> concentration is read from FG-010. The random Read comand assigns "03H" as the register address and reads 2 bytes from the address.

### 3-2-5 Register memory map (Table 12, 13)

Please refer to the document *FG-010 Communication Specifications* for information about each register value, functions, and factory default setting.

## 4. Housing Design

CO<sub>2</sub> gas enters the chamber of FG-010 through a pin hole under the non-woven fabric as shown in Fig. 3. For gas diffusion, it is recommended to separate the device housing from the top of the non-woven fabric by 5mm or more. If quicker response is required, it is recommended that the gas inlet of the sensor be located at the device's slits/opening. It is also recommended to make a small compartment with slits in at least two sides as shown in Fig. 14.

### 1) Sensor compartment



### 2) Slits



Fig. 14 - Example housing design

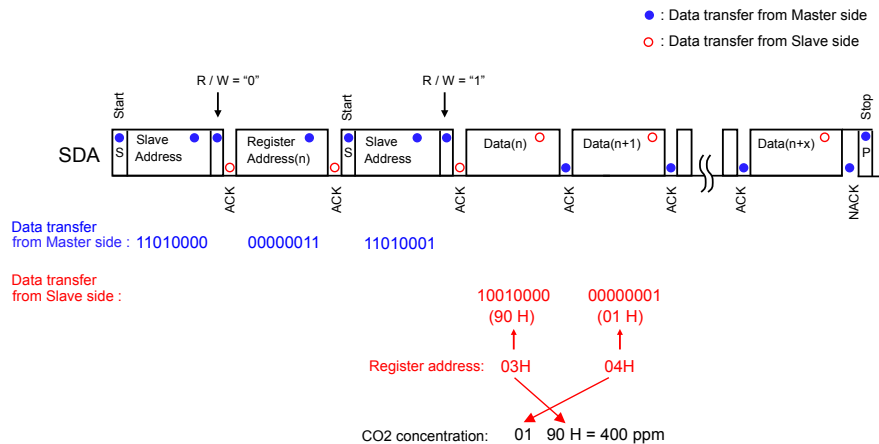

Fig. 13 - Data transfer sequence for random Read command

Address	Name	REG/EEP	Function	Description
00H	RST	REG	Software reset	Resets the module
01H	CTL	EEP	Operating mode	Specifies operating mode
02H	ST1	REG	Status register	Monitors the operating status--read-only
03H	DAL	REG	Low-order CO2 concentration data	Read-only
04H	DAH	REG	High-order CO2 concentration data	Read-only
09H	HPA	EEP	Atmospheric pressure	Specifies atmospheric pressure
0AH	HIT	EEP	Altitude	Specifies altitude
0CH	ALHI	EEP	Upper limit concentration for alarm signal	Specifies upper limit concentration for alarm signal
0DH	ALLO	EEP	Lower limit concentration for alarm signal	Specifies lower limit concentration for alarm signal
0EH	CAL	REG	User calibration	User calibration with I2C
0FH	FUNC	EEP	PWM output	Specifies properties of PWM function, enables/disables PWM, compensates atmospheric pressure and altitude
10H	ERROR	REG	Self diagnosis (error output)	Read-only
12H	AJCON	EEP	CO2 concentration for user calibration	Specifies CO2 concentration (400ppm default)

Table 12 - Register table

Heat is generated at the internal optical source of FG-010. If a temperature sensor is located near the gas sensor, the temperature sensor may not show the correct ambient temperature. In this case, it is recommended to locate a temperature sensor where there is no thermal influence by FG-010. Maintain enough distance from the CO2 sensor or separate the temperature sensor from the CO2 sensor (e.g. by using a thermal insulator).

### 5. Packing (Fig. 15--see p. 12)

50pcs. (25pcs. x 2 layers) of the individually wrapped FG-010 with antistatic bubble sheet is packed in an inner box. 10 inner boxes (FG-010: 50pcs. x 10boxes) are packed in a carton box.

### 6. Maintenance

The single light source, dual wavelength system employed by the FG-010 measures light intensities at two different wavelengths after separation by two optical filters, thus compensating drift due to

accumulated dust and contamination. As a result, there is no need for maintenance.

However, for customers who would like to calibrate periodically, the sensor has a function for air adjustment and zero adjustment. For more detail, please refer to *Sec. 1-8-6. Pin No.7 (CAL)*.

### 7. Handling Precautions

7-1 FG-010 is an ESD-sensitive product. No ESD protection components such as zener diodes or varistors are used in this product. It is recommended that ESD protection equipment be used for handling the module during assembly of application products. ESD protection components and/or an ESD protection enclosure should be used as required for the intended application when this module is embedded into finished products.

7-2 If sensors are dropped, please do not use them. Sensors may be damaged by mechanical shock.

Address	Name	D7	D6	D5	D4	D3	D2	D1	D0
00H	RST	-	-	-	-	-	-	-	REST
01H	CTL	-	-	-	-	-	CTL2	CTL1	CTL0
02H	ST1	BUSY	ALARM	-	-	-	-	CAD0	MSEL
03H	DAL	D7	D6	D5	D4	D3	D2	D1	D0
04H	DAH	-	D14	D13	D12	D11	D10	D9	D8
09H	HPA	Hpa7	Hpa6	Hpa5	Hpa4	Hpa3	Hpa2	Hpa1	Hpa0
0AH	HIT	Hit7	Hit6	Hit5	Hit4	Hit3	Hit2	Hit1	Hit0
0CH	ALHI	Alhi7	Alhi6	Alhi5	Alhi4	Alhi3	Alhi2	Alhi1	Alhi0
0DH	ALLO	Allo7	Allo6	Allo5	Allo4	Allo3	Allo2	Allo1	Allo0
0EH	CAL	-	-	-	-	-	-	Zero-A	Air-A
0FH	FUNC	-	-	-	-	PWMR	HPAE	-	PWME
10H	ERROR	-	-	-	-	-	-	-	Error0
12H	AJCON	Ajcon7	Ajcon6	Ajcon5	Ajcon4	Ajcon3	Ajcon2	Ajcon1	Ajcon0

Table 13 - Register map

## 8. Frequently Asked Questions

Q1: *Is it possible to measure up to 10,000ppm? Can 400ppm or less concentration be measured?*

A: The measurable CO<sub>2</sub> concentration output range through communication is from 0~10,000ppm. However, accuracy may be less than specifications at less than 300ppm or higher than 5,000ppm. The maximum PWM output range is 5,000ppm.

Q2: *What kind of component is used for the optical source and detector element?*

A: A incandescent lamp is used as an optical source and a photodiode is used for the detector element.

Q3: *There is a hysteresis by 100ppm between the high and low alarm thresholds. Is it possible to change the hysteresis?*

A: Yes, hysteresis can be changed. Please refer to "ALHI and ALLO" register of Register and EEPROM in the document FG-010 Communication Specifications.

Q4: *Can the sensor be operated by 3V?*

A: No.

Q5: *Can analog output be obtained?*

A: By converting the PWM output signal, an analog output voltage can be easily made. Please refer to Fig. 4 in Sec. 1-8-3 Pin No.4 (PWM).

Q6: *What is the sensor's life expectancy?*

A: Expected sensor life of FG-010 is 10 years or more.

### **IMPORTANT NOTICE**

*This product is designed for use in indoor air quality control systems, including variable air volume systems and demand controlled ventilation systems. Please consult Figaro prior to use of this product in other applications. This product is not designed and authorized for use as a critical component in life support applications wherein a failure or malfunction of the products may result in injury or threat to life.*

*Figaro Engineering Inc. reserves the right to make changes without notice to this product to improve reliability, functioning or design.*

# COMMUNICATIONS SPECIFICATIONS

Contents	page
1. Overview .....	2
2. Specifications	
2-1 Absolute maximum ratings .....	3
2-2 Recommended operating conditions .....	3
2-3 Electrical characteristics .....	3
3. Connection Methods	
3-1 UART communication .....	4
3-2 I2C communication .....	4
4. Description of Basic Operations	
4-1 Reset function .....	5
4-2 Operation modes .....	5
5. UART Communication - Description of Operation	
5-1 Overview .....	6
5-2 Communication conditions .....	6
5-3 Overview of Modbus protocol .....	6
5-4 Configuration of message .....	6
5-5 Function codes .....	7
5-6 Detail of messages .....	8
6. I2C Communication - Description of Operation	
6-1 Overview .....	14
6-2 Data transfer .....	14
6-3 Data change .....	14
6-4 Start and stop conditions .....	14
6-5 Acknowledge .....	15
6-6 Slave address .....	15
6-7 WRITE instruction .....	16
6-8 READ instruction .....	18
7. List of Registers (Applicable to Both UART and I2C)	
7-1 Register memory map .....	18
7-2 Detailed description of each register .....	20
Appendix 1 (Configuration of Modbus Registers) .....	25
Appendix 2 (Specifications of I2C Bus Interface) .....	27

## 1. Overview

The CDM7160 can control communication with the external controller and the I2C bus or the UART interface and obtain CO2 concentration. Use the MSEL pin to select the I2C bus or UART.

(1) MSEL = L

I2C bus interface is used for communication with the controller.

(2) MSEL = H

UART interface is used for communication with the controller.

\*The MSEL pin is a pull-up input. If this pin is not connected, the UART interface is used.



## 2. Specifications

### 2-1 Absolute maximum ratings

V<sub>SS</sub> = 0 V

Item	Sign	Min.	Max.	Unit
Source voltage (V <sub>DD</sub> )	V; <sub>+</sub>	-0.3	+6.5	V
Input voltage	V <sub>IN</sub>	-0.3	(V <sub>+</sub> )+0.3	V
Input current	I <sub>IN</sub>	-	±10	mA
Storage temperature	T <sub>ST</sub>	-30	+70	°C

(Note 1) If one or more of these values are exceeded during use, the module could be damaged.

In such case, normal operation is not guaranteed.

### 2-2 Recommended operating conditions

V<sub>SS</sub> = 0 V

Item	Remark	Sign	Min.	Typ.	Max.	Unit
Operation temperature		T <sub>a</sub>	0		+50	°C
Source voltage		V <sub>DD</sub>	4.75	5.0	5.25	V

### 2-3 Electrical characteristics

Unless otherwise specified, the following conditions are used:

V<sub>DD</sub> = 4.75V ~ 5.25V, Temperature range = 0°C ~ 50°C

DC characteristics

Item	Sign	Pin	Condition	Min.	Typ.	Max.	Unit
High-level input voltage 1	VIH1	MSEL		80%V <sub>DD</sub>			V
Low-level input voltage 1	VIL1	CAL				20%V <sub>DD</sub>	V
Input current	I <sub>IN</sub>	CAD0		-125		+125	nA
High-level input voltage 2	VIH2	CAD1		70%V <sub>DD</sub>			V
Low-level input voltage 2	VIL2	RX				30%V <sub>DD</sub>	V
Low-level output voltage 1	VOL1	UART_R/T	(Note 2)			0.6	V
High-level output voltage	VOH	ALARM	(Note 3)	V <sub>DD</sub> -0.7			V
Low-level output voltage 2	VOL2	PWM	(Note 2)			0.6	V
Power consumption	IDD1	TX	Power down mode		-	-	μA
	IDD2	VDD	Continuous operation mode 1		8	60	mA

(Note 2) I<sub>OL</sub> = 8 mA, V<sub>DD</sub> = 5V

(Note 3) I<sub>OH</sub> = 3.5 mA, V<sub>DD</sub> = 5V

### 3. Connection Methods

#### 3-1 UART communication

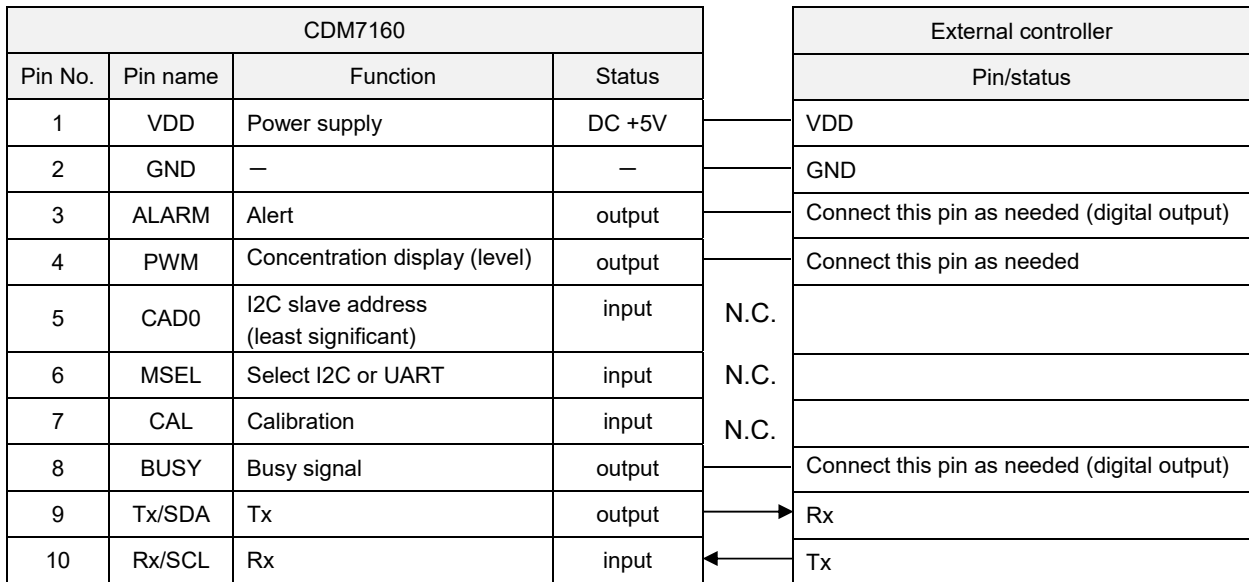
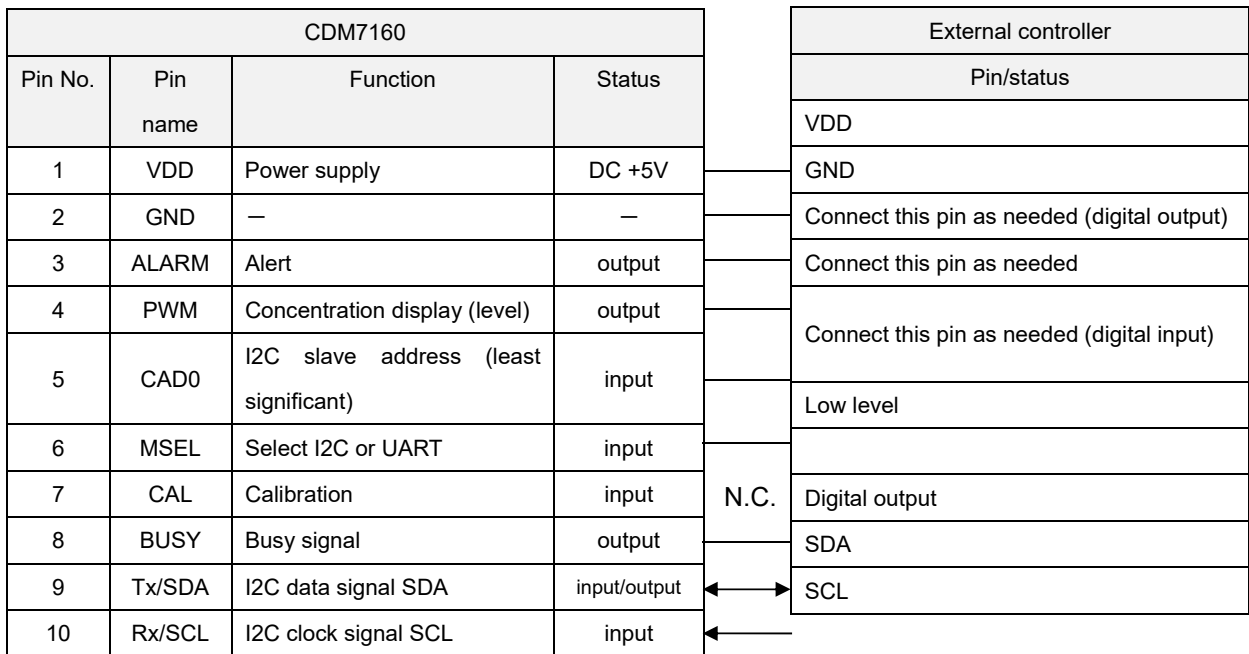

Figure 1 - UART Communication Connection

#### 3-2 I2C communication



Operation sequence from the viewpoint of the External Controller (master) Connection

- (1) Send the start condition
- (2) Send the slave address
- (3) Receive acknowledgement (abbreviated as Ack.) from the CDM7160
- (4) Send the register address to be accessed
- (5) Receive acknowledgement (abbreviated as Ack.) from the CDM7160
- (6) Repeat steps (4) and (5)
- (7) Send the stop bit

## 4. Description of Basic Operations

### 4-1 Reset function (applicable to both UART and I2C)

The CDM7160 is reset when the power is turned on. The CDM7160 also has a soft reset function.

#### Soft reset

The CDM7160 can be reset by writing 1 to the REST bit in the RST register through the UART interface. When reset is complete, the REST bit automatically returns to 0.

### 4-2 Operation modes (applicable to both UART and I2C)

CDM7160 has the following two operation modes:

- (1) Power down mode
- (2) Continuous operation mode 1

The corresponding operation mode can be activated by setting a value in the CTL register.

- (1) Power down mode

The master clock stops and all analog circuits are turned off.

- (2) Continuous operation mode 1

When continuous operation mode 1 is set, analog circuits start operating. The following series of operations will commence:

A) First, measurement of CO<sub>2</sub> concentration starts after a determined setup time. At this time, 1 is set to the BUSY bit in the ST1 register and H is set to the BUSY pin.

B) The first measurement of CO<sub>2</sub> concentration ends after about 0.3 sec. At this time, 0 is set to the BUSY bit in the ST1 register and L is set to the BUSY pin.

Immediately thereafter, the analog circuit stops and enters into low power consumption mode.

C) After 1.7 seconds, the analog circuits operate again and automatically start measuring CO<sub>2</sub> concentration. At this time, 1 is set to the BUSY bit in the ST1 register and H is set to the BUSY pin.

D) This measurement of CO<sub>2</sub> concentration ends after about 0.3 seconds and 0 is set to the BUSY bit in the ST1 register and L is set to the BUSY pin. CO<sub>2</sub> concentration data is now ready to be read. External devices can detect this change and read the concentration data from the DAL and DAH registers.

Immediately thereafter, the analog circuit stops and enters into low power consumption mode.

After this, repeat step C) -- measurement is done again.

Measurement is repeated until operation mode is changed by overwriting the value in the CTL register.

\*To change the alarm and other settings, switch to power down mode, change set conditions, and move back to continuous operation mode.

The operation sequence is shown in the figure below:

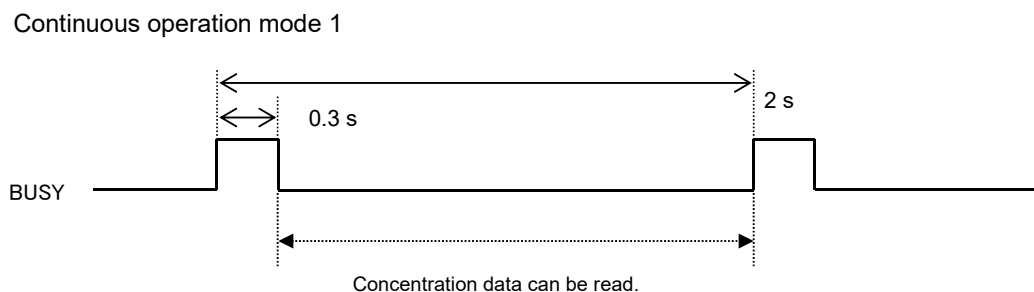

Figure 3 - Continuous Operation Mode

## 5. UART Communication - Description of Operation

### 5-1 Overview

When H is set on the MSEL pin, the CDM7160 uses UART communication mode. As the UART interface is used for communication with the external controller, the TX/SDA pin and the RX/SCL pin operate as TX and RX, respectively, with the communication protocol based on the Modbus protocol.

For details on Modbus specifications, refer to [www.modbus.org](http://www.modbus.org).

### 5-2 Communication conditions

UART communication by the CDM7160 supports only the following limited specifications:

- (1) Only the RTU mode to send 1-byte (8-bit) data is supported. ASCII mode is not supported.
- (2) Supported communication speed is 9600 bps only.
- (3) Both for transmission and reception, no parity bit is used, the start bit is 1 bit, and the stop bit is 1 bit.

The logic of the start bit is L while the logic of the stop bit is H.

(Reference) A 10-bit data string used to send 1-byte data is defined as one character. The time to send one character is about 1.04 ms at 9600 bps.

### 5-3 Overview of Modbus protocol

According to Modbus protocol, the master always sends messages while the slave responds to them.

The controller is the master device while the CDM7160 is the slave device.

The transmission procedure is as follows:

- (1) The master sends the command message to the slave.
- (2) The slave checks if the device address contained in the received message matches its local station.
- (3) When the device address matches, the slave performs processing according to the function code and returns a response message.
- (4) When the device address does not match, the slave discards the received message and waits for the next message.

3.5 or more space characters are required before and after each message.

1.5 or less space characters are required between characters in the message.

### 5-4 Configuration of message

The command message from the master and the response message from the slave consist of four sections: device address, function code, data section, and error check code, which are sent in this order.

Each of these sections is described below:

#### 1. Device address (1 byte)

Number to identify the slave. For the time being, only FEH, which corresponds to all addresses, is supported.

#### 2. Function code (1 byte)

Code to specify the function to be executed by the slave.

For details, refer to "5-5 Function codes."

#### 3. Data section (2 to 17 bytes)

Data required to complete the function code. The configuration of the data section differs depending on the function code. For details, refer to "5-6 Details of messages."

#### 4. Error check code (2 bytes)

Code to detect errors in the message during signal transmission.

CRC16-IBM (Rightward transmission, Initial value: 0xFFFF, Generating polynomial value: 0xA001) is used in the RTU mode for Modbus protocol. The calculation range is from the start of the message (device address) to the end of the data section.

The slave calculates the CRC of the received message and does not respond if it does not match the received CRC code.

Device address	Function code	Data section	Error check code (CRC-16)
1 byte	1 byte	2 to 17 bytes	2 bytes

Configuration of Message

### 5-5 Function codes

The CDM7160 only supports the six types of function codes shown in the table below. The length of the data section differs depending on the function code.

Param. No.			Length of data section		
Function code	Function	Target	Command	Response (at normal time)	
03H	Read	Holding register	4 bytes	3 to 17 bytes	Checks the CAL execution status with UART
04H	Read	Input register	4 bytes	3 to 17 bytes	Reads CO2 concentration data with UART
06H	Write	Holding register	4 bytes	4 bytes	Executes CAL with UART
44H	Read	CO2 concentration data	3 bytes	2 to 17 bytes	Dedicated to reading CO2 concentration data with UART
64H	Write	Register for CDM7160	2 bytes	2 bytes	Writes the register value with UART
65H	Read	Register for CDM7160	2 bytes	2 to 17 bytes	Reads the register value with UART

Function Codes

## 5-6 Details of messages

This section individually describes each function code.

### Reading from the holding register [Function code: 03H]

#### Structure of command message

Message structure (byte)		Example	Remark
Device address		FEH	All devices
Function code		03H	
Read start address	High-order	00H	
	Low-order	00H	
Number of read words	High-order	00H	Up to 8 words (16 bytes)
	Low-order	01H	
CRC data	High-order	90H	
	Low-order	05H	

#### Structure of response message

##### At normal time

Message structure (byte)		Example	Remark
Device address		FEH	All devices
Function code		03H	
Number of read bytes		02H	Number of words ×2
First read data	High-order	00H	Contents at address 0 Acknowledgment register
	Low-order	20H	
CRC data	Low-order	ADH	
	High-order	88H	

##### When read start address > 001FH or (Read start address + Number of read words) > 0020H

Message structure (byte)		Example	Remark
Device address		FEH	All devices
Function code		83H	
Exception code		02H	Illegal Data Address
CRC data	Low-order	F0H	
	High-order	C1H	

##### When the message length excluding CRC is not six bytes or when the number of read words is zero or larger than eight

Message structure (byte)		Example	Remark
Device address		FEH	All devices
Function code		83H	
Exception code		03H	Illegal Data Value
CRC data	Low-order	31H	
	High-order	01H	



Reading from the input register [Function code: 04H]

Structure of command message

Message structure (byte)		Example	Remark
Device address		FEH	All devices
Function code		04H	
Read start address	High-order	00H	
	Low-order	00H	
Number of read words	High-order	00H	Up to 8 words (16 bytes)
	Low-order	04H	
CRC data	Low-order	E5H	
	High-order	C6H	

Structure of response message

At normal time

Message structure (byte)		Example	Remark
Device address		FEH	All devices
Function code		04H	
Number of read bytes		08H	Number of words ×2
First read data	High-order	00H	Contents at address 0 Meter Status
	Low-order	00H	
Second read data	High-order	00H	Contents at address 1 Alarm Status
	Low-order	00H	
Third read data	High-order	00H	Contents at address 2 Output Status
	Low-order	00H	
Fourth read data	High-order	01H	Contents at address 3 CO2concentration
	Low-order	90H	
CRC data	Low-order	16H	
	High-order	E6H	

When read start address > 001FH or (Read start address + Number of read words) > 0020H

Message structure (byte)		Example	Remark
Device address		FEH	All devices
Function code		84H	
Exception code		02H	Illegal Data Address
CRC data	Low-order	F2H	
	High-order	F1H	

When the message length excluding CRC is not six bytes or when the number of read words is zero or larger than eight

Message structure (byte)		Example	Remark
Device address		FEH	All devices
Function code		84H	
Exception code		03H	Illegal Data Value
CRC data	Low-order	33H	
	High-order	31H	

Writing to the holding register [Function code: 06H]

Structure of command message

Message structure (byte)		Example	Remark
Device address		FEH	All devices
Function code		06H	
Write start address	High-order	00H	Writes 0000H to address 0
	Low-order	00H	
Write data	High-order	00H	
	Low-order	00H	
CRC data	Low-order	9DH	
	High-order	C5H	

Structure of response message

At normal time

Message structure (byte)		Example	Remark
Device address		FEH	All devices
Function code		06H	
Write address	High-order	00H	Returns written data
	Low-order	00H	
Write data	High-order	00H	
	Low-order	00H	
CRC data	Low-order	9DH	
	High-order	C5H	

When write address > 1FH

Message structure (byte)		Example	Remark
Device address		FEH	All devices
Function code		86H	
Exception code		02H	Illegal Data Address
CRC data	Low-order	F3H	
	High-order	91H	

When the message length excluding CRC is not six bytes

Message structure (byte)		Example	Remark
Device address		FEH	All devices
Function code		86H	
Exception code		03H	Illegal Data Value
CRC data	Low-order	32H	
	High-order	51H	



Reading CO2 concentration data [Function code: 44H]

Structure of command message

Message structure (byte)		Example	Remark
Device address		FEH	All devices
Function code		44H	
Read start address	High-order	00H	
	Low-order	08H	
Number of read bytes		02H	
CRC data	Low-order	9FH	
	High-order	25H	

\*Only the message in the above command message example can be used.

Structure of response message

At normal time

Message structure (byte)		Example	Remark
Device address		FEH	All devices
Function code		44H	
Number of read bytes		02H	
CO2 concentration data	High-order	01H	Contents at address 3 (CO2 concentration) is indirectly read
	Low-order	90H	
CRC data	Low-order	B9H	
	High-order	18H	

When read start address > 03FFH or (Read start address + Number of read words) > 0400H

Message structure (byte)		Example	Remark
Device address		FEH	All devices
Function code		A4H	
Exception code		02H	Illegal Data Address
CRC data	Low-order	EBH	
	High-order	31H	

When the message length excluding CRC is not five bytes or when the number of read bytes is 0

Message structure (byte)		Example	Remark
Device address		FEH	All devices
Function code		A4H	
Exception code		03H	Illegal Data Value
CRC data	Low-order	2AH	
	High-order	F1H	

Writing to the register for CDM7160 [Function code: 64H]

Structure of command message

Message structure (byte)		Example	Remark
Device address		FEH	All devices
Function code		64H	CDM7160 unique code
Write address		01H	
Write data		06H	Writes to address 1 CTL: Control
CRC data	Low-order	F1H	
	High-order	81H	

Structure of response message

At normal time

Message structure (byte)		Example	Remark
Device address		FEH	All devices
Function code		64H	CDM7160 unique code
Write address		01H	
Write data		06H	Returns written data
CRC data	Low-order	F1H	
	High-order	81H	

When write address > 0FH

Message structure (byte)		Example	Remark
Device address		FEH	All devices
Function code		E4H	
Exception code		02H	Illegal Data Address
CRC data	Low-order	DAH	
	High-order	F1H	

When the message length excluding CRC is not four bytes

Message structure (byte)		Example	Remark
Device address		FEH	All devices
Function code		E4H	
Exception code		03H	Illegal Data Value
CRC data	Low-order	1BH	
	High-order	31H	

The writable address range is from 00H to 0FH.

Reading from the register for CDM7160 [Function code: 65H]

Structure of command message

Message structure (byte)		Example	Remark
Device address		FEH	All devices
Function code		65H	CDM7160 unique code
Read start address		00H	
Number of read bytes		05H	Up to 16 bytes
CRC data	Low-order	E1H	
	High-order	D0H	

Structure of response message

At normal time

Message structure (byte)		Example	Remark
Device address		FEH	All devices
Function code		65H	CDM7160 unique code
Number of read bytes		05H	
First read data		00H	RST: Software reset
Second read data		06H	CTL: Control
Third read data		01H	ST1: Status 1
Fourth read data		90H	DAL: Low-order CO2 concentration data
Fifth read data		01H	DAH: High-order CO2 concentration data
CRC data	Low-order	07H	
	High-order	18H	

When write address > 0FH

Message structure (byte)		Example	Remark
Device address		FEH	All devices
Function code		E5H	
Exception code		02H	Illegal Data Address
CRC data	Low-order	DBH	
	High-order	61H	

When the message length excluding CRC is not four bytes or when (Read start address + Number of read bytes) > 0FH

Message structure (byte)		Example	Remark
Device address		FEH	All devices
Function code		E5H	
Exception code		03H	Illegal Data Value
CRC data	Low-order	1AH	
	High-order	A1H	

The readable address range is from 00H to 0FH.

## 6. I2C Communication - Description of Operation

### 6-1 Overview

When the MSEL pin is set to L, CDM7160 operates with I2C communication. As the I2C bus interface is used for communication with the external controller, the TX/SDA pin and the RX/SCL pin operate as SDA and SCL, respectively. The UART\_R/T/BUSY pin operates as the BUSY signal output pin.

For the I2C bus interface in the CDM7160, standard mode (up to 100 kHz) or high-speed mode (up to 400 kHz) can be selected. (For details on the I2C bus interface, refer to Appendix 2, "Specifications of I2C Bus Interface" at the end of this document.)

### 6-2 Data transfer

The start condition must be first input to access the CDM7160 via the bus.

Next, the 1-byte slave address containing the device address is sent. At this time, the CDM7160 compares the received slave address with its own slave address. When these addresses match, the CDM7160 generates an acknowledgement and executes the read or write instruction. To end the instruction, input the stop condition.

### 6-3 Data change

SDA line data can be changed while the clock on the SCL line is at Low. While the clock signal on the SCL line is High, the status of the SDA line must be constant. (Data on the SDA line can be changed only while the clock signal on the SCL line is Low.)

While the SCL line is High, the status of data on the SDA line is changed only when the start or stop condition is input.

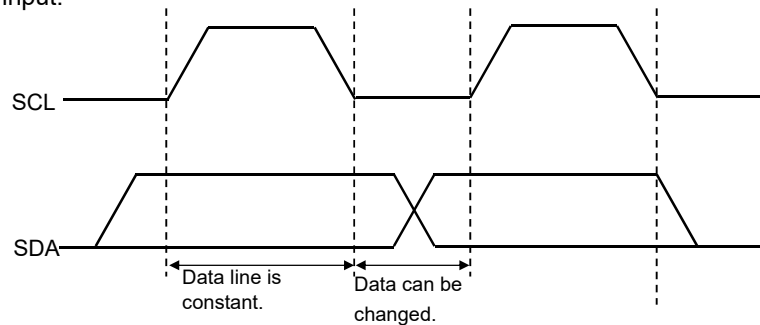

Figure 4 - Data Change

### 6-4 Start and stop conditions

If the SDA line is changed from High to Low while the SCL line is High, the start condition is generated.

All data transfer starts with the start condition.

If the SDA line is changed from Low to High while the SCL line is High, the stop condition is generated.

All data transfer ends with the stop condition.

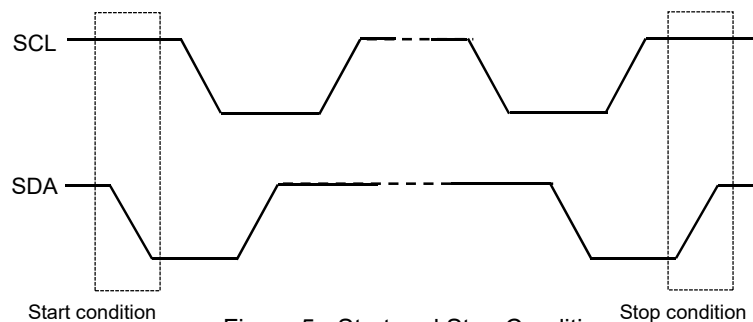

Figure 5 - Start and Stop Conditions



### 6-5 Acknowledgement

The device that sends data opens the SDA line after sending 1-byte data (High status). The device that receives the data sets Low to the SDA line at the next clock. This operation is called acknowledgement. Acknowledgement allows checking if data transfer has been successfully completed.

The CDM7160 generates acknowledgement after receiving the start condition and the slave address.

When executing the WRITE instruction, CDM7160 generates acknowledgement when receiving each byte.

When executing the READ instruction, CDM7160 generates acknowledgement and sends data stored at the specified address. The CDM7160 then opens the SDA line and monitors it. If the master device generates acknowledgement instead of the stop condition, the CDM7160 sends the 8-bit data stored at the next address. If acknowledgement is not generated, the CDM7160 stops sending data.

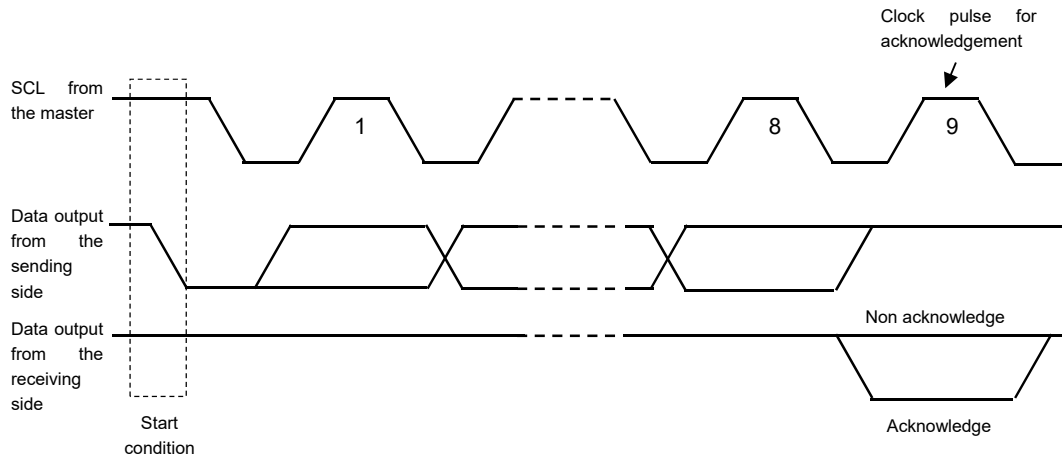

Figure 6 - Generation of Acknowledgement

### 6-6 Slave address

The first byte containing the slave address is input after the start condition. The slave address is used to select the device to be accessed from the devices on the bus.

The slave address consists of the upper 7 bits. The upper 6 bits of the slave address are fixed to 110100 in the CDM7160. The 7th bit is the address bit to select the device to be accessed and is set by the CAD0 pin. When the slave address is input, the device whose address matches generates acknowledgement and then executes the instruction. The eighth bit (the least significant bit) in the first byte is the R/W bit.

When the R/W bit is 1, the READ instruction is executed. When the R/W bit is 0, the WRITE instruction is executed.

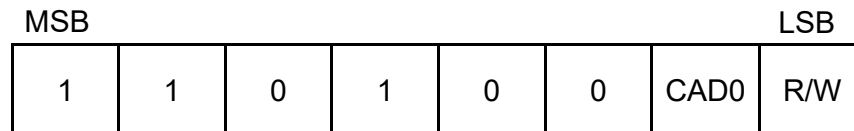

Figure 7 - Slave Address

### 6-7 WRITE instruction <applicable to the register and EEPROM>

When 0 is set to the R/W bit, the CDM7160 executes the write operation.

During the write operation, the CDM7160 receives the start condition and the first byte (slave address), generates acknowledgement, and then receives the second byte. The second byte specifies the address of the internal control register in the MSB first format.

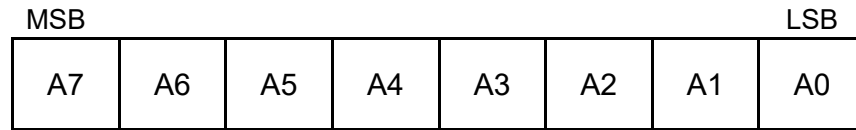

Figure 8 - Register Address

After receiving the second byte (register address), the CDM7160 generates acknowledgement and then receives the third byte.

The third byte represents control data. Control data consists of 8 bits in the MSB first format.

After receiving control data, the CDM7160 generates acknowledgement. Data transfer always ends with the stop condition generated by the master.

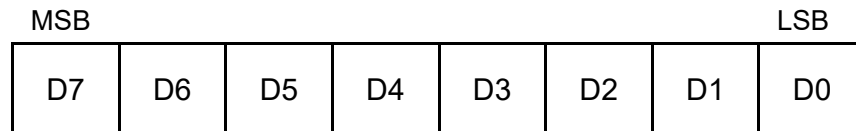

Figure 9 - Control Data

The CDM7160 does not support sequential write. The CDM7160 writes data under the stop condition. If the specified address is write-only, data is not written.

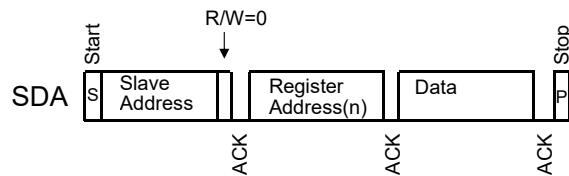

Figure 10 - Write

If the specified address points to EEPROM, the CDM7160 generates acknowledgement after the slave address is sent and after the register address is sent.

If the CDM7160 receives data afterward, clock stretch occurs to ensure the EEPROM write time (Note 1).

When clock stretch ends and SCL is released, the master device generates the stop condition and the write operation ends.

Note 1) The CDM7160 delays the processing at the master device to ensure the EEPROM write time by forcibly setting L to SCL.

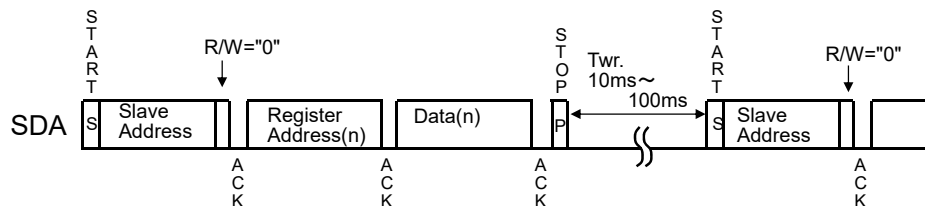

Figure 11 - Write (EEPROM)

### 6-8 READ instruction <applicable to the register and EEPROM>

When 1 is set to the R/W bit, the CDM7160 executes the read operation.

If the master device generates acknowledgement instead of the stop condition after the CDM7160 sends the data from the specified address, data can be read from the next address.

Once the address is counted up to 0FH in the range between 00H and 0FH, the next address returns to 00H.

#### (1) Reading data from the current address

The CDM7160 has an internal address counter. During the operation to read data from the current address, data is read from the address specified at this counter.

The internal address counter retains the address next to the last accessed address.

For example, if the last accessed address for the READ instruction is n, data is read from address n+1 when the instruction to read data from the current address is executed.

When reading data from the current address, the CDM7160 receives the slave address for the READ instruction (R/W bit = 1) and generates acknowledgement. Then, the CDM7160 starts transferring data specified at the internal address counter at the next clock and increments the internal address counter by 1. If the master device generates the stop condition instead of acknowledgement after the CDM7160 sends 1-byte data, the read operation ends.

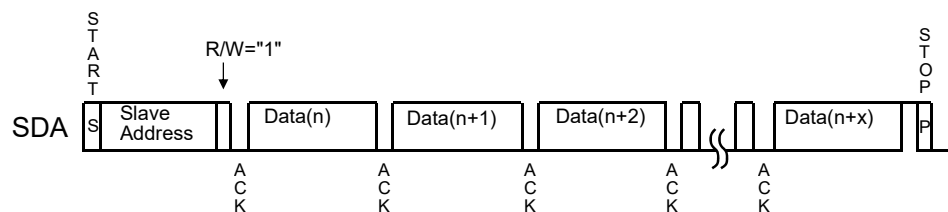

Figure 12 - Reading Data from the Current Address

#### (2) Random read

The random read operation reads data from an arbitrary address.

For random read, the WRITE instruction must be executed as dummy before the slave address for the READ instruction (R/W bit = 1) is sent. During the random read operation, the start condition is first generated and then the slave address for the WRITE instruction and the read address are sent. In response to this address transmission, the CDM7160 generates acknowledgement and then the master device sends the start condition and the slave address for the READ instruction (R/W bit = 1) again. The CDM7160 generates acknowledgement in response to this transmission of slave address. After that, the CDM7160 sends data from the specified address and increments the internal address counter by 1.

If the master device generates the stop condition instead of acknowledgement after sending data, the read operation ends.

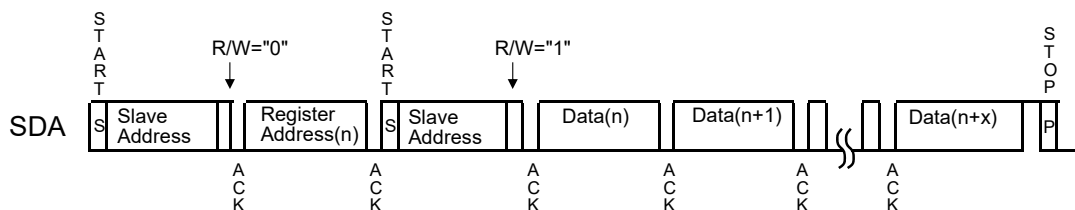

Figure 13 - Random Read

## 7. List of Registers (Applicable to Both UART and I2C)

### 7-1 Register memory map

The CDM7160 has the registers and EEPROM with the addresses shown in Table 1. Each address consists of 8-bit data.

Address	Name	REG/EEP*	Brief description	Description
00H	RST	REG	Soft reset	Resets the module
01H	CTL	EEP	Operation mode	Sets the operation mode
02H	ST1	REG	Status register	Monitors the operation state. Read-only
03H	DAL	REG	Lower CO2 concentration data	Read-only
04H	DAH	REG	Upper CO2 concentration data	Read-only
05H	—		Reserved	Read/write not allowed
06H	—		Reserved	Read/write not allowed
07H	—		Reserved	Read/write not allowed
08H	—		Reserved	Read/write not allowed
09H	HPA	EEP	Atmospheric pressure data	Sets the atmospheric pressure value (hPa)
0AH	HIT	EEP	Altitude data	Sets the altitude value (m)
0BH	—		Reserved	Read/write not allowed
0CH	ALHI	EEP	Upper limit concentration for the alarm signal	Sets the upper limit concentration for the alarm signal
0DH	ALLO	EEP	Lower limit concentration for the alarm signal	Sets the lower limit concentration for the alarm signal
0EH	CAL	REG	User calibration	User calibration with I2C
0FH	FUNC	EEP	Control of each type of function	Sets correction for PWM output, atmospheric pressure and altitude
10H	ERROR	REG	Self-diagnosis (error output)	Read-only
11H	—		Reserved	Read/write not allowed
12H	AJCON	EEP	CO2 concentration for user calibration	Sets the CO2 concentration. (400 ppm set by default)

Table 1 = Register Table

\*REG: The data in the register is initialized when the power is turned off.

EEP: The data in the register is retained even when the power is turned off.

Register map

Address	Name	D7	D6	D5	D4	D3	D2	D1	D0
00H	RST	-	-	-	-	-	-	-	REST
01H	CTL	-	-	-	-	-	CTL2	CTL1	CTL0
02H	ST1	BUSY	ALARM	-	-	-	-	CAD0	MSEL
03H	DAL	D7	D6	D5	D4	D3	D2	D1	D0
04H	DAH	-	D14	D13	D12	D11	D10	D9	D8
05H	—	-	-	-	-	-	-	-	-
06H	—	-	-	-	-	-	-	-	-
07H	—	-	-	-	-	-	-	-	-
08H	—	-	-	-	-	-	-	-	-
09H	HPA	Hpa7	Hpa6	Hpa5	Hpa4	Hpa3	Hpa2	Hpa1	Hpa0
0AH	HIT	Hit7	Hit6	Hit5	Hit4	Hit3	Hit2	Hit1	Hit0
0BH	—	-	-	-	-	-	-	-	-
0CH	ALHI	Alhi7	Alhi6	Alhi5	Alhi4	Alhi3	Alhi2	Alhi1	Alhi0
0DH	ALLO	Allo7	Allo6	Allo5	Allo4	Allo3	Allo2	Allo1	Allo0
0EH	CAL	-	-	-	-	-	-	Zero-A	Air-A
0FH	FUNC	-	-	-	-	PWMR	HPAE	-	PWME
10H	ERROR	-	-	-	-	-	-	-	Error0
12H	AJCON	Ajcon7	Ajcon6	Ajcon5	Ajcon4	Ajcon3	Ajcon2	Ajcon1	Ajcon0

Table 2 - Register Map

Note) Do not write or read data to or from an address other than those above.

## 7-2 Detailed register descriptions

### RST: Soft reset

Address	Register name	D7	D6	D5	D4	D3	D2	D1	D0
Write/read									
00H	RST	-	-	-	-	-	-	-	REST

#### REST: Reset

0: Normal status

1: Reset

The CDM7160 is reset when 1 is written to this bit. When reset ends, this bit automatically returns to 0.

### CTL: Control

Address	Register name	D7	D6	D5	D4	D3	D2	D1	D0
Write/read EEPROM									
01H	CTL	-	-	-	-	-	CTL2	CTL1	CTL0
Reset		0	0	0	0	0	1	1	0

#### CTL<2:0>: Specification of operation mode

Set value			Operation mode
D2	D1	D0	
0	0	0	Power down mode
1	1	0	Continuous operation mode

**\*Note: Do not write a value other than 00H or 06H to the CTL register.**

### ST1: Status 1

Address	Register name	D7	D6	D5	D4	D3	D2	D1	D0
Read-only register									
02H	ST1	BUSY	ALARM	-	-	-	-	CAD0	MSEL
Reset		0	0	0	0	0	0	0	0

#### BUSY: Busy

0: Data can be read.

1: Busy status

The BUSY bit becomes 1 if data cannot be read—for example, during ADC conversion or operation of read data. The controller reads data after confirming that this bit changed from 1 to 0.

The status of this bit is output to the BUSY pin as well.

#### ALARM: Alarm

0: The CO<sub>2</sub> concentration is below 10 times the CO<sub>2</sub>LO value.

1: The CO<sub>2</sub> concentration is above 10 times the CO<sub>2</sub>HI value.

The ALARM bit notifies that the CO<sub>2</sub> concentration exceeds the preset value.

The status of this bit is output to the ALARM pin as well.

#### CAD0, MSEL:

Can monitor the status of the CAD0 and MSEL pins.

\*If there is no connection to the CAD0 pin, the CAD0 is internally pulled up to High status.

### DAL to DAH: CO2 concentration data

Address	Register name	D7	D6	D5	D4	D3	D2	D1	D0
Read-only register									
03H	DAL	D7	D6	D5	D4	D3	D2	D1	D0
04H	DAH	-	D14	D13	D12	D11	D10	D9	D8
Reset		0	0	0	0	0	0	0	0

CO2 concentration data is output to D0 to D14. Concentration data is stored in little endian. The data range is from 0 to 10000 in decimal notation.

CO2 concentration data			CO2 concentration data
Binary	Hexadecimal	Decimal	
X010 0111 0001 0000	2710	10000	10000ppm
X000 0000 0000 0000	0000	0	0ppm

If the concentration is 400 ppm, DAL = 90H and DAH = 01H.

### ALHI: ALARM high threshold data

Address	Register name	D7	D6	D5	D4	D3	D2	D1	D0
Write/read EEPROM									
0CH	ALHI	Alhi7	Alhi6	Alhi5	Alhi4	Alhi3	Alhi2	Alhi1	Alhi0
At shipment		0	1	1	0	0	1	0	0

This register sets the CO2 concentration at which the ALARM bit changes from 0 to 1. When the CO2 concentration data exceeds 10 times the value written to this register, the ALARM bit changes to 1. If ALHI = 64H, the ALARM bit changes to 1 when the CO2 concentration exceeds 1000 ppm.

### ALLO: ALARM low threshold data

Address	Register name	D7	D6	D5	D4	D3	D2	D1	D0
Write/read EEPROM									
0DH	ALLO	Allo7	Allo6	Allo5	Allo4	Allo3	Allo2	Allo1	Allo0
At shipment		0	1	0	1	1	1	0	0

This register sets the CO2 concentration at which the ALARM bit changes from 1 to 0. When the CO2 concentration data drops below 10 times the value written to this register, the ALARM bit changes to 0. If ALLO = 5AH, the ALARM bit changes to 0 when the CO2 concentration drops below 900 ppm. You can add hysteresis by setting a value larger than ALLO to ALHI. Set a value equal to or larger than ALLO to ALHI.

### HPA: hPa (atmospheric pressure)

Address	Register name	D7	D6	D5	D4	D3	D2	D1	D0
Write/read EEPROM									
09H	HPA	Hpa7	Hpa6	Hpa5	Hpa4	Hpa3	Hpa2	Hpa1	Hpa0
At shipment		1	1	0	1	0	1	0	1

Write the atmospheric pressure data to correct atmospheric pressure when calculating CO<sub>2</sub> concentration.

The atmospheric pressure data is expressed as follows:

Atmospheric pressure (hPa) = HPA + 800

When HPA = D5H, the atmospheric pressure is 1013 hPa.

HPA data			Atmospheric pressure
Binary	Hexadecimal	Decimal	
1111 1111	FF	255	1055 hPa
0000 0000	00	0	800 hPa

### HIT: Height (altitude)

Address	Register name	D7	D6	D5	D4	D3	D2	D1	D0
Write/read EEPROM									
0AH	HIT	Hit7	Hit6	Hit5	Hit4	Hit3	Hit2	Hit1	Hit0
At shipment		0	0	0	0	0	0	0	0

Write altitude data to correct the atmospheric pressure when calculating the CO<sub>2</sub> concentration.

The altitude data is expressed as follows:

Altitude (m) = HIT×10

HIT data			Altitude
Binary	Hexadecimal	Decimal	
1111 1111	FF	255	2550 m
0000 0000	00	0	0 m

Note: When writing altitude data, HIT

- When writing the actual altitude (m) value, write the atmospheric pressure at 0 m above sea level to the atmospheric pressure data, HPA.
- When the actual atmospheric pressure (hPa) value has been written to HPA: 0(m) (at the time of shipment)

(Reference): The atmospheric pressure correction value by altitude is simplified to be -1.1 hPa per 10m.

When using the atmospheric pressure and altitude correction functions, set 1 (enabled) to the HAPE bit in the FUNC register (address: 0FH).



### CAL: User calibration

Address	Register name	D7	D6	D5	D4	D3	D2	D1	D0
Write-only register									
0EH	CAL	-	-	-	-	-	-	Zero-A	Air-A
Reset		0	0	0	0	0	0	0	0

**Air-A:** Air Adjustment is executed when the Air-A bit is set to 1 under normal clean atmosphere or to the CO<sub>2</sub> concentration that is pre-set at the register address (12H). After execution of Air Adjustment, the measured concentration value is reset to the pre-set CO<sub>2</sub> value at the register address (12H).

**Zero-A:** Zero Adjustment is executed when the Zero-A bit is set to 1 while the sensor is placed into zero gas. Measured concentration value is reset to 0ppm.

### FUNC: Function setting

Address	Register name	D7	D6	D5	D4	D3	D2	D1	D0
Write/read EEPROM									
0FH	FUNC	-	-	-	-	PWMR	HPAE	-	PWME
At shipment		0	0	0	0	0	0	0	1

This register enables/disables each type of function and sets other conditions.

This register is not initialized even when CDM7160 is reset.

**PWME:** Enables/disables the PWM pin.

0: Disable

1: Enable

When 1 is set to the PWME bit, a 1-kHz square wave with a pulse width that is proportional to the CO<sub>2</sub> concentration is output from the PWM pin.

When 0 is set, the PWM pin is always at high impedance. You can reduce power consumption by setting 0 when not using the PWM pin.

**PWMR:** Sets the concentration range represented by the pulse width output to the PWM pin.

0: High concentration

1: Low concentration

The relationship between the concentration and the pulse width (PW) is expressed by the following expressions:

High concentration: Concentration (ppm) = PW (μs) × 5

Low concentration: Concentration (ppm) = PW (μs) × 2

**HPAE:** Enables/disables atmospheric pressure correction.

0: Disable

1: Enable

When 1 is set to the HPAE bit, the CO<sub>2</sub> concentration is calculated after correcting the atmospheric pressure based on the data written to the HPA and HIT registers. When 0 is set, the CO<sub>2</sub> concentration is calculated assuming an atmospheric pressure of 1013 hPa and altitude of 0m.

### ERROR: Self-diagnosis

Address	Register name	D7	D6	D5	D4	D3	D2	D1	D0
Read-only register									
10H	ERROR	-	-	-	-	-	-	-	Error0
Reset		0	0	0	0	0	0	0	0

#### Error0: Self-diagnosis error

0: No self-diagnosis error

1: Self-diagnosis error generated

The error bit indicates if an error occurred as a result of self-diagnosis. If there is no error, the error bit is 0. If an error occurred, the error bit is 1.

### AJCON: User calibration adjustment concentration

Address	Register name	D7	D6	D5	D4	D3	D2	D1	D0
Write/read EEPROM									
12H	AJCON	Ajcon7	Ajcon6	Ajcon5	Ajcon4	Ajcon3	Ajcon2	Ajcon1	Ajcon0
At shipment		0	0	0	0	1	0	1	0

This register sets the adjustment concentration (target concentration) when executing user calibration.

The default value at the time of shipment is 400 ppm.

The adjustment concentration is expressed as follows:

$$\text{Adjustment concentration (ppm)} = \text{AJCON} \times 10 + 300$$

AJCON data			Adjustment concentration
Binary	Hexadecimal	Decimal	
1111 1111	FF	255	2850ppm
0000 0000	00	0	300ppm

## Appendix 1 (Configuration of Modbus Registers)

The Modbus registers in CDM7160 consist of two independent register groups - input registers and holding registers.

The tables below show their configuration.

Both types of registers are defined by 32 16-bit addresses. Though accessing the reserved section does not cause an error, no operation is performed.

Although the input register supports continuous read, data can be read from up to eight addresses at once.

The address number is the value calculated by subtracting 1 from the register number.

### Input registers

Input registers are read-only registers.

Only IR4 is actually enabled.

IR4 stores the measured CO2 concentration in ppm.

Register No.	Address	Register Name	
IR1~3	0 to 2		Reserved
IR4	3	CO2 concentration	CO2 concentration/ppm
IR5~21	4 to 20		Reserved - returns "illegal data address" exception
IR22	21		Reserved
IR23~32	22 to 31		Reserved - returns "illegal data address" exception

## Holding registers

Register No.	Address	Register Name																
HR1	0	Acknowledgment register	DI 16	DI 15	DI 14	DI 13	DI 12	DI 11	DI 10	DI 9	DI 8	DI 7	DI 6	DI 5	DI 4	DI 3	DI 2	DI 1
			DI1 DI2 DI3 DI4 DI5 DI6 - CO2 air adjustment has been performed DI7 - CO2 zero adjustment has been performed DI8 DI9 DI10 DI11 DI12 DI13 DI14 DI15 DI16															
HR2	1	Special Command Register *	Command								Parameter							
			7CH								06H - CO2 air adjustment 07H - CO2 zero adjustment							
HR3~ 32	2~31		Reserved - returns "illegal data address" exception															

Only HR1 and HR2 are actually enabled.

HR1 supports read/write while HR2 is write-only.

Calibration starts when a value is written to HR2. When calibration is complete, the relevant bit in HR1 becomes 1.

When performing calibration using HR1 and HR2, the following procedure is recommended:

- (1) Write 0 to HR1.
- (2) Write 7C06H (air adjustment) or 7C07H (zero adjustment) to HR2.
- (3) Read HR1 and check that DI6 or DI7 is 1.

## Appendix 2 (Specifications of I<sup>2</sup>C Bus Interface)

The I<sup>2</sup>C bus interface supports the standard mode and the high-speed mode.

### (1) I<sup>2</sup>C BUS START/STOP BITS TIMING

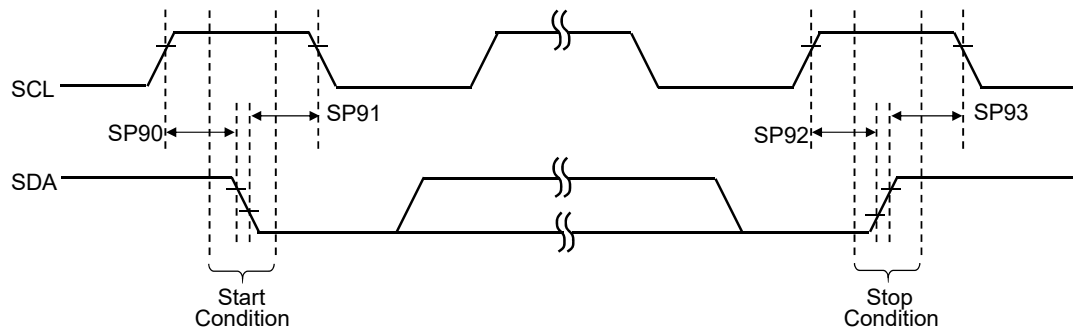

### (2) I<sup>2</sup>C BUS START/STOP BITS REQUIREMENTS

Param. No.	Sign	Item	Min.	Typ.	Max.	Unit	Condition	
SP90	TSU:STA	Start Condition Setup time	100kHz mode	4700	-	-	ns	Only relevant for Repeated Start condition
			400kHz mode	600	-	-		
SP91	THD:STA	Start Condition Hold time	100kHz mode	4000	-	-	ns	After this period, the first clock pulse is generated
			400kHz mode	600	-	-		
SP92	TSU:STO	Stop Condition Setup time	100kHz mode	4700	-	-	ns	
			400kHz mode	600	-	-		
SP93	THD:STO	Stop Condition Hold time	100kHz mode	4000	-	-	ns	
			400kHz mode	600	-	-		

### (3) I<sup>2</sup>C DATA TIMING

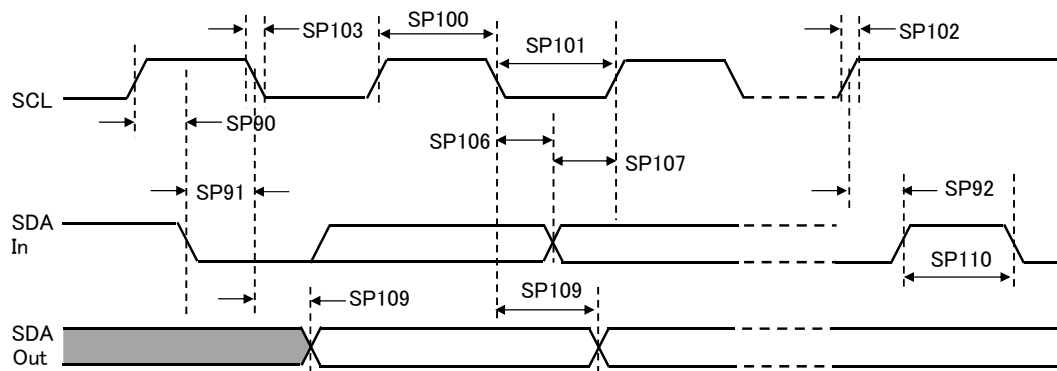

#### (4) I<sup>2</sup>C BUS DATA REQUIREMENTS

Param. No.	Sign	Item	Min.	Max.	Unit	Condition	
SP100	THIGH	Clock high time	100kHz mode	4.0	-	µs	Device must operate at a minimum of 1.5MHz
			400kHz mode	0.6	-	µs	Device must operate at a minimum of 10MHz
			SSP module	1.5Tcy	-		
SP101	TLOW	Clock low time	100kHz mode	4.7	-	µs	Device must operate at a minimum of 1.5MHz
			400kHz mode	1.3	-	µs	Device must operate at a minimum of 10MHz
			SSP module	1.5Tcy	-		
SP102	TR	SDA and SCL rise time	100kHz mode	-	1000	ns	
			400kHz mode	20+0.1C B	300	ns	CB is specified to be from 10-400pF
SP103	TF	SDA and SCL fall time	100kHz mode	-	250	ns	
			400kHz mode	20+0.1C B	250		CB is specified to be from 10-400pF
SP106	THD:DAT	Data input hold time	100kHz mode	0	-		
			400kHz mode	0	0.9		
SP107	TSU:DAT	Data input setup time	100kHz mode	250	-	ns	(Note2)
			400kHz mode	100	-	ns	
SP109	TAA	Output valid from clock	100kHz mode	-	3500	ns	(Note1)
			400kHz mode	-	-	ns	
SP110	TBUF	Bus free time	100kHz mode	4.7	-		Time the bus must be free before a new transmission can start
			400kHz mode	1.3	-		
SP111	CB	Bus capacitive loading	-	-	400		

Note1: As a transmitter, the device must provide this internal minimum delay time to bridge the undefined region (min. 300ns) of the falling edge of SCL in order to avoid unintended generation of Start or Stop conditions

Note2: A Fast mode (400 kHz) I<sup>2</sup>C™ bus device can be used in a Standard mode (100 kHz) I<sup>2</sup>C bus system, but the requirement TSU:DAT ≥ 250ns must then be met. This will automatically be the case if the device does not stretch the low period of the SCL signal. If such a device does stretch the low period of the SCL signal, it must output the next data bit to the SDA line TR max. + TSU:DAT = 1000 + 250 = 1250ns (according to the Standard mode I<sup>2</sup>C bus specification), before the SCL line is released.