

CO2 & Oxygen Monitor Operating Instructions

Model: RAD-0200-2

Table of Contents

1. Overview
2. Package Contents and Description
3. Strobes (Optional)
4. LCD Display Symbols
5. SEU (Main Sensor Unit)
6. RDU (Remote Display Unit)
7. Installation
8. Advanced Management Settings
9. Customizing the Settings
10. Caring for the Monitor
11. Specifications
12. Weight & Dimensions
13. Safety Notice
14. Fault Codes & Troubleshooting Guide
15. Support and Warranty

1. Overview

Thank you for purchasing the RAD-0200-2 CO2 and Oxygen Monitor and Alarm. This device monitors carbon dioxide and oxygen levels in confined spaces. Low concentrations of oxygen and/or high concentrations of CO2 are dangerous, and may lead to health problems ranging from headaches and fatigue to asphyxiation and death. The RAD-0200-2 CO2 & Oxygen Monitor's alarm will activate when the oxygen concentration is lower than the pre-set level or the CO2 concentration exceeds the pre-set level. This will also activate a relay that can turn on a fresh air fan or notify staff or first-responders that a problem exists.

Features

- Large digital LCD display indicates CO2 and oxygen levels in real time
- 3 CO2 and 3 Oxygen Alarms meet OSHA codes
- Sensor Unit can control up to 3 Remote Display Units
- 3 relay output can automatically control fans to ventilate confined spaces
- Audible and visual alarms
- Automatic altitude compensation (can be turned on/off)
- 4-20 mA output for offsite monitoring
- 100% clean look by burying all cables in the wall
- Allows for field upgrades with strobe package at a later date

2. Package Contents and Description

The RAD-0200-2 package comprises the following parts. Please check that all parts are available when the box is opened.

Sensor Main Unit (SEU)	Remote Display Unit (RDU)	Mounting Brackets (2 pcs.)
CAT 5 Communication Cable (1 pc.)	Relay Cables (3 pcs.)	Wall Plug Safety Strap (1 pc.)
Power Supply (Pre-Wired)	International Power Adaptors (3 pcs.)	Screws (13 pcs.)
Wall Anchors (12 pcs.)	Cable Clips (10 pcs.)	User Manual (1 pc.)
Warning Signs (6 pcs.)		

3. Strobes (Optional)

The strobes are optional visible alarms that augment the flashing red Alarm LEDs on the SEU and RDU. They are activated when the oxygen or carbon dioxide alarms are activated.

Each Strobe comes with a CAT 5 cable that plugs into the SEU or RDU.

4. LCD Display Symbols

Symbol	Meaning	Description
	CO2 and O2 Concentration	Ambient CO2 concentration in ppm (parts per million) and O2 concentration in % volume
	Alarm	Alarm icon
DIAG	Diagnostics	Test communications between the SEU and RDU
AL1 O2	Oxygen Alarm 1	Displayed when setting oxygen alarm 1. If O2 concentration falls below AL1, the AL1 (Red 1 LED) and Fault LED will flash, the buzzer will sound, relay 1 will be triggered, and strobes (if attached) will flash. Alarm will not shut off unless reset or powered off. (Latched See 8.1)
AL2 O2	Oxygen Alarm 2	Displayed when setting oxygen alarm 2. If O2 level falls below AL2, the AL1 (Red 1 LED), AL2 (Red 2 LED) and Fault LED will flash, the buzzer will sound, relay 1 and relay 2 will be triggered, and strobes (if attached) will flash. Alarm will not shut off unless reset or powered off. (Latched See 8.1)
AL3 O2	Oxygen Alarm 3	Displayed when setting oxygen alarm 3. If O2 level falls below AL3, all 3 AL (Red LEDs) and the Fault LED will flash, the buzzer will sound, all 3 relays will be triggered, and strobes (if attached) will flash. Alarm will not shut off unless reset or powered off. (Latched See 8.1)
AL1 CO2	CO2 Alarm 1 (5,000 ppm OSHA TWA)	Displayed when setting CO2 alarm 1. If CO2 level stays above 5,000ppm TWA (time weighted average) relay 1 will be triggered, AL1 (Red 1 LED) will flash but the buzzer will not sound. If CO2 returns to normal and not latch alarm will shut off.
AL2 CO2	CO2 Alarm 2	Displayed when setting CO2 alarm 2. If CO2 level goes above AL2 level, relay 1 and relay 2 will be triggered, AL1 (Red 1 LED) and AL2 (Red 2 LED) will flash, the buzzer will sound and strobes will flash (if attached). If CO2 returns to normal and not latched (see sec. 8.1) alarm will shut off.
AL3 CO2	CO2 Alarm 3	Displayed when setting CO2 alarm 3. If CO2 level goes above AL3 level, relays 1, 2 and 3 will all be triggered, all 3 AL (Red LEDs) and the Fault LED will flash, the buzzer will sound and strobes will flash if attached. Alarm will not shut off unless reset or powered off. (Latched See 8.1)
CALI	Calibration Mode	To calibrate the O2 and CO2 sensor when the accuracy drift
ReFS	Recover Factory Settings	To recover factory default settings and cancel any customized settings.
HI	High	O2 level above 25% or CO2 level above 5%.
	Fan Icon	Displays when alarm is on

5. SEU (Main Sensor Unit)

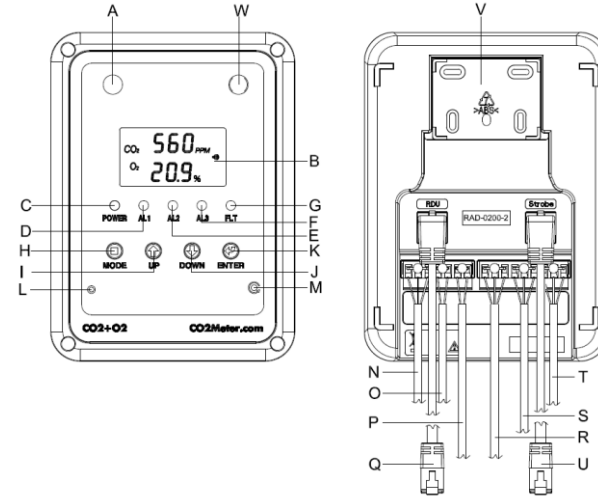

- A. CO2 Sensor
- B. LCD display
- C. Power Indicator
- D. Red 1 LED (AL1)
- E. Red 2 LED (AL2)
- F. Red 3 LED (AL3)
- G. Yellow LED (Fault indication)
- H. Mode Button
- I. UP Button
- J. Down Button
- K. Enter Button
- L. Buzzer
- M. Reset Button
- N. 4-20mA Output
- O. Battery Bkup
- P. DC Power
- Q. Cable to RDU
- R. Relay for AL3
- S. Relay for AL2
- T. Relay for AL1
- U. CAT5 Cable to Strobe (optional)
- V. Panel Holder
- W. O2 Sensor

The SEU (Sensor Unit) contains both an electro-chemical oxygen sensor and an NDIR carbon dioxide sensor. CO2 and O2 levels are monitored in ambient air through ports A and W on the SEU and reported in real time on the LCD display.

All connections are made to the SEU including power, alarm relays, 4-20mA output, battery backup, connection to the RDU, and optional strobes.

All functions and custom alarm settings are made on the SEU. The "DIAG" function tests communication between the SEU and RDU. If setup is done incorrectly, the "RCFS" function can be used to return the monitor to the original factory settings.

The Power (Green LED) will light continuously when the power is supplied. If the device is powered by a battery, the Power (Green LED) will flash and the battery indicator will appear and change with the battery voltage.

If the communication cable between the SEU & RDU is not securely connected, the yellow Fault LED will blink. If the communication cable is inserted into the wrong port on the RDU, after about one minute the "Er7" will flash on the RDU LCD. Plug the cables into the correct ports on RDU and the unit will work normally.

CO2 Alarm

If the SEU detects a 5,000ppm CO2 TWA (time-weighted average over 8 hours) level, the AL1 (Red 1 LED) and strobes will flash, the buzzer will sound, and relay 1 will be triggered. When the CO2 TWA value drops below 5000ppm (with 5% hysteresis) the relay will reset and the monitor will return to normal

If the CO2 level exceeds the AL2 CO2 levels, Red AL1 and AL2 LEDs will flash, the buzzer will sound, the strobes will flash, and the AL1 and AL2 relays will be triggered. If the CO2 level exceeds the AL3 CO2 levels, all Red Alarm LEDs and the FLT LED will flash, the buzzer will sound, the strobes will flash, and all 3 relays will be triggered.

If the CO2 level drops to normal, the flashing and buzzer will stop, but the Fault LED will remain flashing (if Latch is set on see 8.1). Once CO2 levels are normal, the alarms can be reset by pressing the reset button or by unplugging the unit.

Oxygen Alarm

When the SEU detects oxygen levels below the AL1 O2 value, the AL1 (Red 1 LED), FLT LED and strobes will flash, the buzzer will sound, and relay 1 will be triggered. Once O2 levels are normal, the alarms can be reset by pressing the reset button or by unplugging the unit.

When the SEU detects an oxygen levels below the AL2 or AL3, the alarm actions will be repeated. Once O2 levels are normal, the alarms can be reset by pressing the reset button or by unplugging the unit. (if Latched See 8.1)

6. RDU (Remote Display Unit)

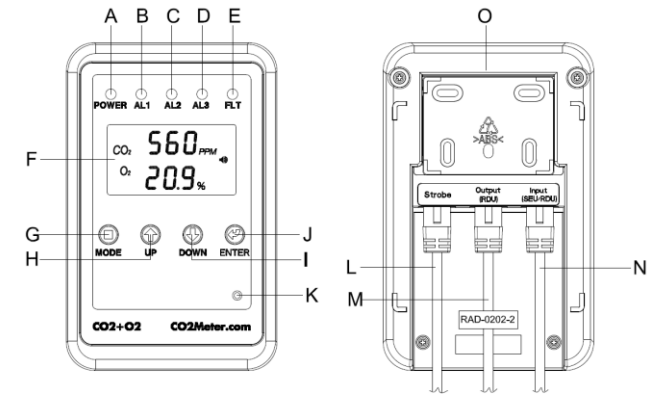

- A. Power Indicator
- B. Red 1 LED (AL1)
- C. Red 2 LED (AL2)
- D. Red 3 LED (AL3)
- E. Yellow LED (Fault or Warning)
- F. LCD display
- G. Mode Button
- H. UP Button
- I. down Button
- J. Enter Button
- K. Buzzer
- L. CAT 5 Cable for Strobe (Optional)
- M. CAT 5 Out Cable for next RDU (Optional)
- N. CAT 5 Cable for SEU or last RDU (Input)
- O. Panel Holder

The RDU displays the data from the SEU and provides visual and audible indication that the SEU is in alarm status. The RDU is NOT an external/second sensor. The RDU is connected to the SEU with a CAT 5 cable. A 25-foot CAT 5 cable is provided. Users can source additional cable lengths as needed. The RDU should be placed where it can be conveniently observed (eye level) before entering the room/space.

The "DIAG" function can be used to test the communication between the SEU and RDU. Resetting the monitor is only available from SEU.

7. Installation

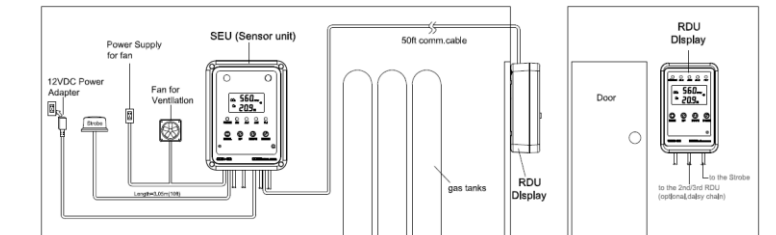

1. Choose a suitable location to install the SEU 18 inches (0.5m) from the floor where the gas is stored. Fix the panel holder on the wall with four screws provided.
2. The SEU has been pre-wired for 3 alarm relays, 4-20mA output and 6V DC batter backup. Remove any wires you do not plan to use, then attach the SEU to the panel holder.
3. Fix the second panel holder in a suitable location outside the monitored space at eye level, typically next to a door. Attach the RDU to panel holder.
4. Route the included 25 ft. CAT 5 cable between the SEU and RDU using the nail cable clips to secure the cable to the wall. Up to 3 daisy chained RDUs and up to 300 ft. total length of CAT 5 cable may be used.
5. Connect the RDU to the SEU paying careful attention to the CAT 5 labels on each unit.
6. If you have purchased add-on strobes, connect them to the RDU and SEU.
7. Connect the power. The SEU and RDU will begin to operate.
8. Use the "DIAG" function (Sec. 10.3) on the SEU or RDU to verify communication between the units. The five LED's will blink and the buzzer will sound on both the SEU & RDU. The display should read the same on both units.
9. Complete the installation by attaching the power plug lock and putting the safety signs up around the RDU. They must be visible whether the door is open or closed.
10. Attaching relays 1-3 to fresh air fans or HVAC control systems. See our video for detailed instructions on connecting to the relays.

8. Advanced Management Settings

These settings use a non-obvious key combination to prevent casual users from changing alarm settings. In most cases, the default settings are recommended. To access the Advanced Management Settings press the Up + Enter key combination for 10 seconds.

8.1) Latch function: On or off, default is on.

When Latch is on, the Yellow Fault light will continue to flash after an alarm has activated indicating that at some time in the past the monitor entered alarm status. Unplug the unit to reset the Fault light.

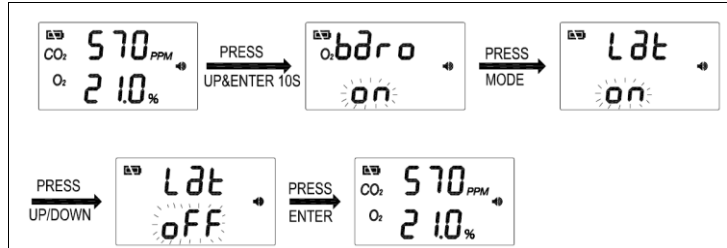

1. Press Up & Enter button for 10 seconds
2. Change to Advance Mode by pressing Mode, and choose Lat Mode
3. Press Up/Down to set Latch Mode On or Off.
4. Press Enter to Save.

8.2) Alarm level lock: Lock / unlock. Default is Lock.

If the alarm level is locked, none of the alarms can be changed without first turning the Alarm level lock off.

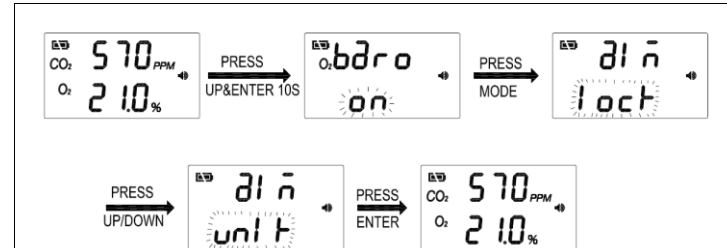

1. Press Up & Enter button for 10 seconds.
2. Change to Advance Mode by press Mode, and choose Alm Mode
3. Press Up/Down to set ALn to lock or unlock
4. Press Enter button to Save

8.3) Barometric Compensation: On / Off. Default is on.

When on, the monitor automatically compensates for barometric pressure / altitude. There are separate on/off setting for CO2 and O2.

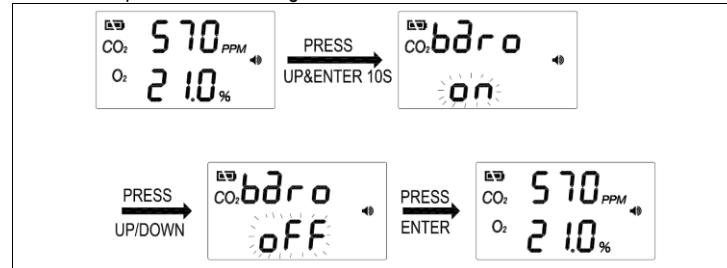

1. Press Up & Enter button for 10 seconds
2. Change to Advance Mode by press Mode, and choose Baro Mode
3. Press Up/Down to set bAro On or Off
4. Press Enter to Save

9. Customizing the Settings

When power is first turned on, all LEDs will flash and the buzzer will sound 4 times as part of the internal self-check diagnostics. After self-check diagnostics are complete, the following settings can be changed on the SEU.

NOTE: If there is 6V DC on the Battery backup (See O. on the SEU diagram) all custom settings will be saved in the event of power loss. Otherwise, each time the power is turned off, the monitor will return to factory default settings.

9.1 Select Temperature Units:

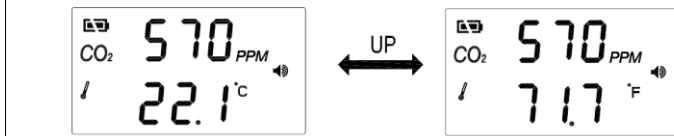

1. Press "Up" button to switch between °C and °F.

9.2 Select Barometric Units:



1. Press "Down" to switch between hPa and inHg.

9.3 DIAG function: Manually perform self-check diagnostics.

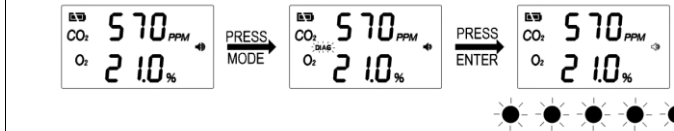

1. Press Mode until the "DIAG" icon flashes.
2. Press Enter.
3. The five LED's will blink and the buzzer will sound on the SEU and RDU simultaneously.

9.4 Verify AL1 CO2: 5,000ppm OSHA TWA (not user configurable).



1. Press Mode until the "AL1" and "CO2" icons are flashing.
2. Press Enter. Verify the current AL1 CO2 level is fixed at 5,000ppm.
3. Press Enter again to save or press Mode to exit without saving.

9.5 Setting CO2 AL2 Level: (first Unlock the Alarm Level – See 8.2)

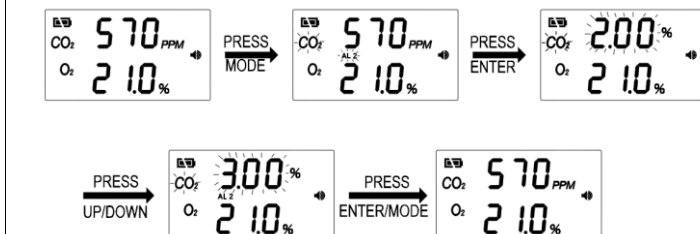

1. Press Mode until the "AL2" and "CO2" icons are flashing.
2. Press Enter. The current AL2 CO2 level will flash.
3. Press Up/Down to select 5,000ppm, 1%, 1.5%, 2%, 2.5%, or 3% alarm level.
4. Press Enter to save or press Mode to exit without saving.

9.6 Setting CO2 AL3 Level: (first Unlock the Alarm Level – See 8.2)

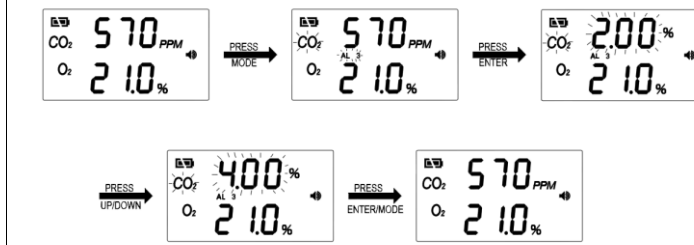

1. Press Mode until the "AL3" and "CO2" icons are flashing.
2. Press Enter. The current AL3 CO2 level will flash.
3. Press Up/Down to select 2%, 2.5%, 3%, 3.5%, or 4% alarm level.
4. Press Enter to save or press Mode to exit without saving.

Note: CO2 AL3 must be HIGHER than CO2 AL2 to work properly.

9.7 Setting O2 AL1 Level: (first Unlock the Alarm Level – See 8.2)

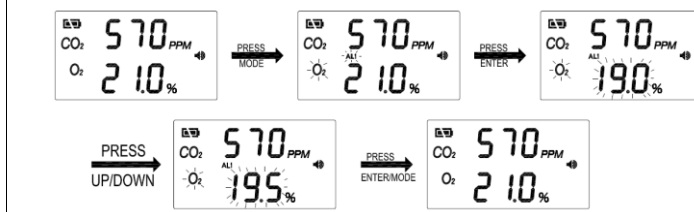

1. Press Mode until the "AL1" and "O2" icons are flashing.
2. Press Enter. The current AL1 O2 level will flash.
3. Press Up/Down to select 18%, 18.5%, 19%, 19.5% or 20% O2 alarm levels.
4. Press Enter to save or press Mode to exit without saving.

9.8 Setting O2 AL2 Level: (first Unlock the Alarm Level – See 8.2)

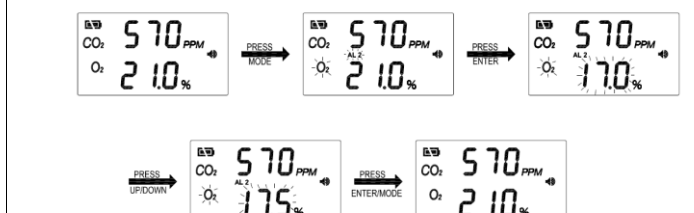

1. Press Mode until the "AL2" and "O2" icons are flashing.
2. Press Enter. The current AL2 O2 level will flash.
3. Press Up/Down to select 16%, 16.5%, 17%, or 17.5% O2 alarm levels.
4. Press Enter to save or press Mode to exit without saving.

9.9 Setting O2 AL3 Level: (first Unlock the Alarm Level – See 8.2)

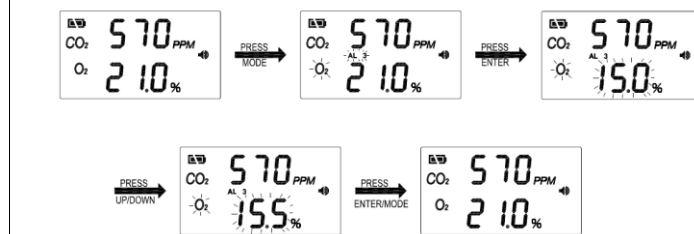

1. Press Mode until the "AL3" and "O2" icons are flashing.
2. Press Enter. The current AL3 O2 level will flash.
3. Press Up/Down to select 13%, 13.5%, 14%, 14.5%, 15%, or 15.5% O2 alarm levels.
4. Press Enter to save or press Mode to exit without saving.

9.10 Calibration:

Zero and Span Calibration should both be performed at least annually. They can be performed onsite or the SEU can be returned for factory calibration. Check your state or local code for calibration schedule requirements in your jurisdiction.

What you will need: a test gas cylinder of pure nitrogen (0ppm CO2 and 0% O2), a cylinder of 21% oxygen, a regulator, and tubing. If you are calibrating on site, first inform occupants to ignore the alarms while calibration takes place.

Part 1: CO2 ZERO Calibration:

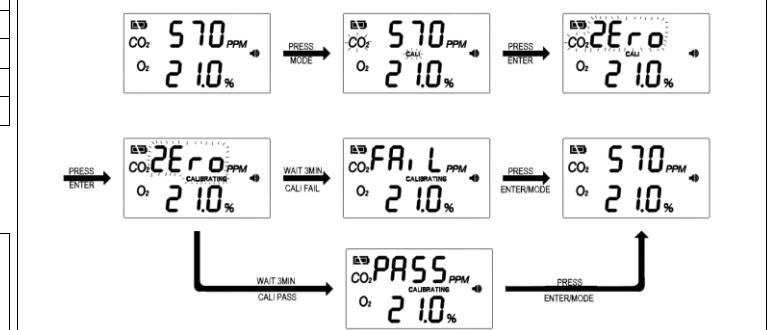

1. Hold the tubing from the Nitrogen (0ppm CO2) gas cylinder to the CO2 sensor opening on the top left-hand corner of the SEU.
2. Open the gas regulator. Set the flow rate between 0.15-0.50 liters per minute.
3. Wait until the CO2 reading on the SEU settles consistently at or near 0ppm CO2 on the screen.
4. Press the Mode button until you see the "CO2" and "CALI" icons flash.
5. Press Enter to view the calibration settings. The words "CO2" and "ZEro" will begin flashing on the LCD.
6. Press Enter again to begin calibrating. "CALIBRATING" will begin flashing.
7. After approximately 3 minutes, the LCD will display either "PASS" or "FAIL."
8. If the LCD reads "FAIL", repeat the steps again. If it displays "PASS", press Enter. The display should now show 0ppm
9. Remove the nitrogen gas.
10. Press the Reset button at the bottom right-hand side of the SEU front cover.

Part 2: Oxygen ZERO Calibration:

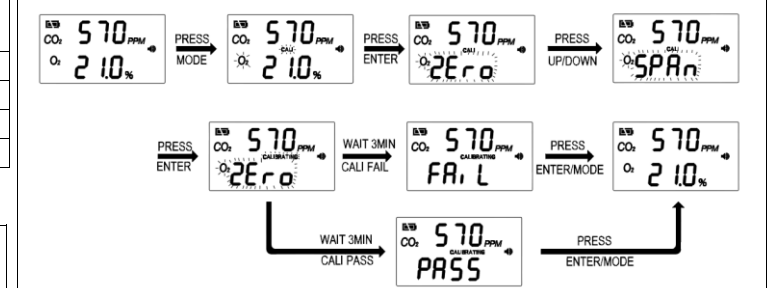

1. Hold the tubing from the Nitrogen (0% O2) gas cylinder to the oxygen sensor opening on the top right-hand corner of the SEU.
2. Open the gas regulator. Set the flow rate between 0.15-0.50 liters per minute.
3. Wait until the O2 reading on the SEU settles consistently at or near 0% O2 on the screen. All alarms will be triggered.
4. Press the Mode button until the "O2" and "CALI" icons flash.
5. Press Enter to view the calibration settings. The words "O2" and "ZEro" will begin flashing on the LCD.
6. Press Enter again to begin calibrating. "CALIBRATING" will begin flashing.
7. After approximately 3 minutes, the LCD will display either "PASS" or "FAIL"
8. If the LCD reads "FAIL", repeat the steps again. If it displays "PASS", press Enter. The display should now show 0%
9. Remove the nitrogen gas.
10. Press the Reset button at the bottom right-hand side of the SEU front cover.

Part 3: Oxygen SPAN Calibration:

1. Hold the tubing from the 21% oxygen gas cylinder to the oxygen sensor opening on the top right-hand corner of the SEU.
2. Open the gas regulator. Set the flow rate between 0.15-0.50 liters per minute.
3. Wait until the O2 reading on the SEU settles consistently at or near 21% O2 on the screen.
4. Press the Mode button until the "O2" and "CALI" icons flash.
5. Press Enter to view the calibration settings. The words "O2" and "ZEro" will begin flashing on the LCD.
6. Press the Up or Down arrow key to change from "Zero" to "SPAN".
7. Press Enter again to begin calibrating. "CALIBRATING" will begin flashing.
8. After approximately 3 minutes, the LCD will display either "PASS" or "FAIL".
9. If the LCD reads "FAIL", repeat the steps again. If it displays "PASS", press Enter. The display should now show 21% O2.
10. Remove the oxygen gas cylinder.
11. Press the Reset button at the bottom right-hand side of the SEU front cover.

Note: If your unit fails either "ZEro" or "SPAN" calibration, please follow the procedure again before calling support.

9.11 Using ReFS - Recover Factory Settings: Fixes incorrect alarm settings or calibration problems by returning monitor to original factory settings.

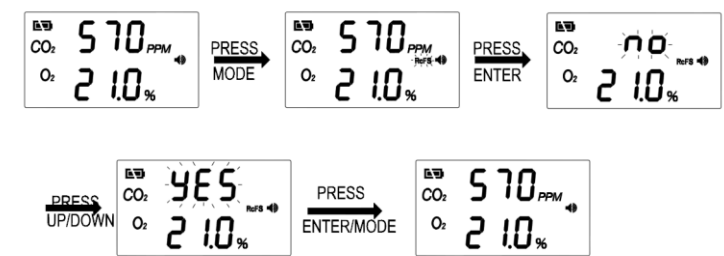

1. Press Mode until the "ReFS" icon flashes. Press Enter.
2. Press Up/Down to choose either "Yes" or "No".
3. Press Enter to save or press Mode to exit without saving.

10. Caring for the Monitor

To make sure to receive the maximum benefit from using this monitor, please observe the follow guidelines.

1. **Repair** – Do not attempt to repair the monitor or modify the circuitry by yourself. Please contact your dealer or a qualified repairman if the monitor needs servicing.
2. **Cleaning** – Disconnect the power before cleaning. Use a damp cloth. Do not use liquid cleaning agents such as benzene or paint thinners as these will damage the device.
3. **Maintenance** – We recommend using the DIAG function to test communication between the SEU and RDU and to verify they are working properly. If the five LEDs blink and the buzzers sound simultaneously, it indicates that SEU and RDU are working normally.

11. Specifications

■ Sensor Specifications:

CO2 Sensor Specifications	
Measurement Range	0 - 50,000ppm (5%) display
Display Resolution	10ppm at 0~10,000ppm; 100ppm at 10,001~50,000ppm
Accuracy	+/- 200ppm or +/- 10% of the reading
Pressure Dependence	Automatic pressure compensation via built in barometric sensor (50 to 110 kPa)
Response Time	< 2 minutes for 90% response
CO2 AL1	5000ppm fixed OSHA TWA
CO2 AL2	5000, 1%, 1.5%, 2%, 2.5%, 3% Default AL2 is 1.5%.
CO2 AL3	2%, 2.5%, 3%, 3.5%, 4%. Default is 3.0%
Sound Alarm	80db@10cm
Warm-Up Time	< 60 seconds at 72°F (22°C)

Oxygen Sensor Specifications

Measurement Range	0 - 25% display
Display Resolution	0.1%
Accuracy	Better than 2%FS
Pressure Dependence	Automatic pressure compensation via built in barometric sensor (500-1200 mbar)
Response Time	< 2 minutes for 90% response
O2 AL1	18%, 18.5%, 19%, 19.5%, 20%. Default AL1 is 19%.
O2 AL2	16%, 16.5%, 17%, 17.5%. Default AL2 is 17%
O2 AL3	13%, 13.5%, 14%, 14.5%, 15%, 15.5%. Default is 15%.
Sound Alarm	80db@10cm
Warm-Up Time	< 60 seconds at 72°F (22°C)

Temperature Sensor Specifications

Temperature Range	32°F to 122°F (0°C to 50°C)
Display Resolution	0.1°F (0.1°C)
Display Options	°C/°F
Accuracy	±2.7°F (±1.5°C) when O2 concentration is below first alarm level
Response Time	20-30 minutes (case must equalize with environment)

■ Operating Conditions:

Operating Temperature	32°F to 122°F (0°C to 50°C)
Humidity Range	0 ~ 95% RH non-condensing

Storage Conditions:

Storage Temperature	-4°F to 140°F (-20°C to 60 °C)
---------------------	--------------------------------

■ Power Supply

Power Supply	DC	9~32VDC (12~32VDC recommended), 2A.
	AC adapter	Input: 100~240 VAC, 50/60Hz, 0.6A Output: 12VDC, 2000mA.
Battery	Voltage	6VDC (5.4V~7.0V), recommended capacity is 12AH

■ Relay Outputs

Relay 1	AL1 for CO2 and O2
Relay 2	AL2 for CO2 and O2
Relay 3	AL3 for CO2 and O2

The Peak current for all relay are less than 2A@30 VDC or 250 VAC, SPDT.

■ 4-20mA Outputs

CL01:4-20mA	CO2:0~50,000ppm
CL02:4-20mA	O2: 0~25%

13. Weight & Dimensions

SEU	Weight	16.9 oz. (478 g)
	Dimensions (LxWxD)	6.69 x 4.96 x 2.73 inches
RDU	Weight	6.9 oz. (197 g)
	Dimensions (LxWxD)	5.51 x 3.54 x 1.89 inches

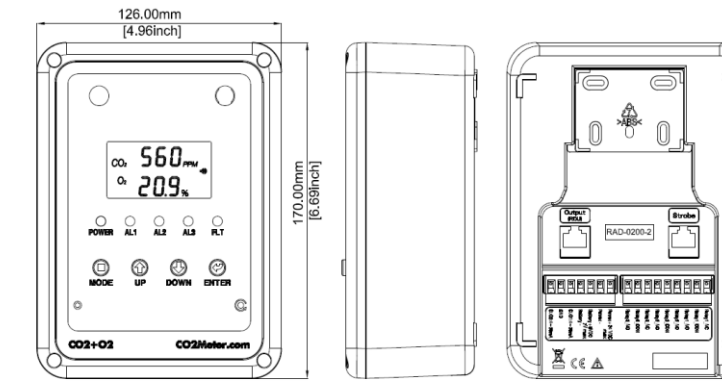

SEU (Sensor Unit)

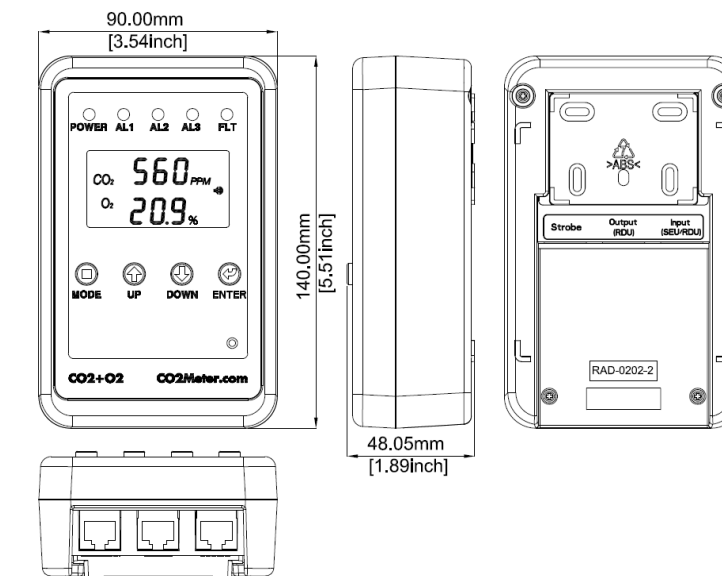

RDU (Remote Display Unit)

14. Safety Notice

Your safety is very important to us. To ensure to use the product correctly and safety, please read these warnings and the entire User Manual before using the product. Otherwise, the protection provided by the equipment may be impaired. These warnings provide important safety information and should be observed at all times.

1. Do not subject the monitor to impact or shock.
2. Do not place the monitor or the adaptor near a heat source
3. Do not open the monitor or touch exposed electronic circuitry under any circumstances as there is danger of electric shock.
4. Use only the included power adaptor. Improper power adaptors or power sources can damage to the product, or result in injury or fire.
5. Make sure that the power adaptor is secured tightly by a plug lock so that it cannot be disconnected accidentally or by hand.
7. Do not enter an enclosed area if the alarm is sounding. Careful and protective action must be taken before entering the room where the SEU is installed.
8. Dry contact relays cannot provide power to external devices like a ventilation fan. If there is no power supply to the fan, the relay will not work. This may result in potential danger with high CO2 concentration in confined space.

15. Fault Codes & Troubleshooting Guide

This section includes a list of Frequently Asked Questions for problems you may encounter with the RAD-0200-2 O2 Monitor.

No	LCD Fault Icon	Description (of the fault)	SEU Indication	RDU Indication	Suggested Actions
1	Er3	The ambient temperature has exceeded the temperature range 0°C to 50°C (32°F to 122°F)	"Er3" flashes, Yellow Fault LED blinks	"Er3" flashes, Yellow Fault LED blinks	This error will disappear when the temperature returns to the normal operating range between 32°F to 122°F (0°C and 50°C)
2	Er5	EEPROM System Problem	"Er5" flashes, Yellow Fault LED blinks	"Er5" flash, Fault LED blink	Power on again or press reset button. If "Er5" continues, contact local dealer.
3	Er7	Internal Data Transmission Error	"Er7" flashes, Yellow Fault LED blinks	"Er7" flashes, Yellow Fault LED Blinks	Check the CAT 5 plug is connected into the INPUT port of RDU, if the "Er7" displays on the RDU only. Press reset button on SEU or power on again

16. Support & Warranty

Contact us: We're here to help!

If the troubleshooting guide above doesn't help you solving your problem or for more information, please contact us using the information below.

✉ Support@CO2Meter.com
☎ (386) 256-4910 (M-F 9:00am-5:00pm EST)
🌐 www.CO2Meter.com

See CO2Meter, Inc. Terms & Conditions at www.CO2Meter.com/pages/terms-conditions



CO2Meter, Inc.

131 Business Center Drive
Ormond Beach, FL 32174
Phone: 386-872-7665 | Fax: 866-422-2356
Email: Sales@CO2Meter.com