

# MX200 Sensor Controller Manual

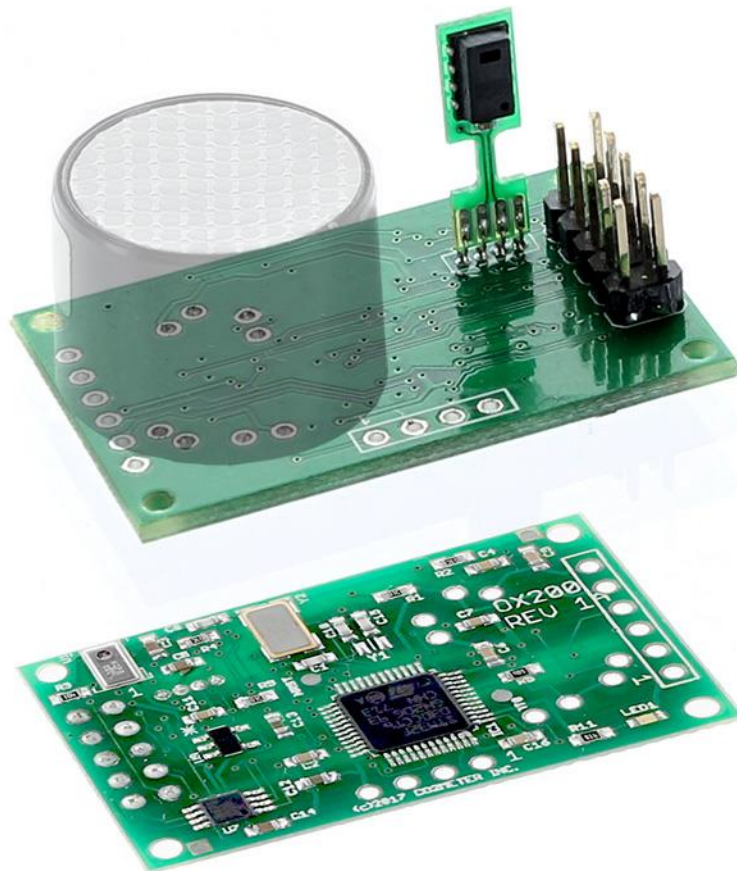

The information in this document is protected under applicable federal law as an unpublished work and is confidential and proprietary to Co2Meter Inc. Its use, disclosure, reproduction, or publication, in whole or in part, without the express prior written consent of Co2Meter, Inc. is prohibited.

© 2018 CO2METER, INC. All Rights Reserved.

## Document History

<b>Date</b>	<b>Revision</b>	<b>Description</b>
<b>30 June, 2017</b>	A	Initial Draft
<b>1 October, 2017</b>	B	Initial Release
<b>12 October, 2017</b>	C	Published to website
<b>13 October, 2017</b>	D	Added dimensional drawing
<b>19 February 2018</b>	E	For Firmware 3.xx Remove unused commands, confirm analog output add configuration tables and scaler values for Analog out.
<b>19 February 2018</b>	F	Firmware ver. 3 build 2. Parameters 6-gas type, 11 full scale analog for 3 volts, 12 scaling multipliers 1, 10, 100
<b>28 February 2018</b>	G	Firmware ver. 3 build 4. RS485 “!” command finalized. “\$” pass thru command for GSS applications.
<b>1 March 2018</b>	H	Firmware ver. 3 Build 5. “#” Restart command, Pin 2 PWM, Error codes, Aux signal doc.
<b>2 March 2018</b>	J	Firmware ver. 3 build 5. PWM time base parameter.
<b>14 March 2018</b>	K	Firmware OX200v3b008. RS485 support

## Table of Contents

<b>INTRODUCTION.....</b>	<b>5</b>
ABOUT THIS MANUAL.....	5
<b>CHAPTER 1 : OVERVIEW.....</b>	<b>6</b>
GENERAL.....	6
MEASUREMENTS .....	6
Unfiltered Raw Reading (V).....	6
Filtered or calibrated concentration (Z) .....	6
Temperature (T).....	6
Humidity (H).....	6
Barometric Pressure (B).....	6
Dimensional Drawing.....	7
Definition of AUX pins for reference.....	8
<b>CHAPTER 2 : COMMUNICATIONS INTERFACE.....</b>	<b>9</b>
GENERAL.....	9
PHYSICAL CONNECTIONS .....	9
CONNECTOR ASSIGNMENTS.....	9
RS485 INPUT .....	9
PWM OUTPUT.....	10
ANALOG OUTPUT .....	10
GPIO INPUT .....	10
LINK LEVEL PARAMETERS.....	10
TTL PROTOCOL.....	10
MODES .....	10
COMMANDS .....	11
Error Codes: .....	11
B Command – Get Barometric Pressure from on- board Barometer.....	11
b Command – Get Barometric Pressure from UV o2 sensor internal Barometer.....	12
G Command – Get Sensor Type.....	12
H Command – Get Relative Humidity.....	12
K Command – Set Communications Mode – Not implement.....	13
P Command – Set Parameter to Value .....	13
p Command – Get Parameter Value .....	13
Q Command – Get Readings -not implemented.....	14
T Command – Get Temperature (O2 UV Flux sensor) .....	14
t Command – Get Temperature (On board RH & T sensor).....	14
U Command – Zero Calibrate.....	15
u Command – Set Zero Calibration Point.....	15
V Command – Get Unfiltered Gas (CO2) Un calibrated (O2) Concentration .....	15
W Command – Write Current Parameter Values to Flash.....	16
w Command – Restore Parameters to Default .....	16
X Command – Calibrate to specified concentration (SPAN) .....	17
x Command – Reserved for Factory Use.....	17
Y Command – Report Device Identification .....	17
Z Command – Get Filtered Gas Concentration.....	18
# Command – Restart.....	18
\$ Command – pass thru character string to GSS.....	18
% Command – Get Partial Pressure.....	19

<i>. Command – Get Multiplier</i> .....	19
RS 485 INTERFACE COMMANDS .....	19
<i>! Command – Select Device</i> .....	20
<b>CHAPTER 3 : CONFIGURATION</b> .....	<b>21</b>
<i>Configuration Option Word (4)</i> .....	22
<i>PWM time base (14)</i> .....	22
<b>CHAPTER 4 : CALIBRATION</b> .....	<b>23</b>
BASIC CALIBRATION .....	23
<b>CHAPTER 5 : SUPPORT</b> .....	<b>24</b>
WARRANTY .....	24
LIABILITY .....	24
RETURNS .....	24
CONTACT US .....	25

## Introduction

### About this Manual

This document is a technical reference for the CO2Meter.com MX200 Sensor Controller. It provides the information necessary to use the sensor controller as well as information about configuring the controller for various applications. The sensors currently supported include the SprintIR6S CO2 Sensors, MinIR CO2 Sensors and UV Flux Oxygen Sensors. Please visit our website [www.CO2Meter.com](http://www.CO2Meter.com) for product information.

## Chapter 1 : Overview

### General

The MX200 Sensor Controller is a high-performance controller supporting various types of gas sensor modules. The controller supplies a UART interface to the host system and a separate UART interface to the gas sensor module. The controller also has onboard Barometric Pressure, Temperature, and Humidity Sensors. The onboard microprocessor provides facilities for adding additional calibration and compensation functions that enhance the utility of the sensors.

In addition, the MX200 has an RS485 interface that supports the attachment of multiple sensors in a network using twisted pair cable.

In typical applications, the sensor samples once per second and filters readings over 8 seconds.

### Measurements

The MX200 makes several measurements, typically once per second. The descriptions below, the letter in parenthesis is that used to report the value on the communication interface.

#### *Unfiltered Raw Reading (V)*

This is the raw value Uncalibrated O<sub>2</sub> value from UV sensor (O) or the unfiltered (averaged) CO<sub>2</sub> value (Z).

#### *Filtered or calibrated concentration (Z)*

Calibrated O<sub>2</sub> value (Zero & Spanned) or CO<sub>2</sub> value Zero & Spanned and filtered (averaged)  
This is the filtered gas concentration compensated for temperature and optionally pressure.

#### *Temperature (T)*

This is the temperature reading from temperature/humidity sensor device.

#### *Humidity (H)*

This is the Relative Humidity reading from the temperature/humidity sensor device.

#### *Barometric Pressure (B)*

For models equipped with a barometric sensor, this is the barometric pressure. This value is corrected by the microprocessor for linearity and temperature using values determined during manufacturing of the sensor. Barometric Pressure is valid only in the range from 500 – 1150 millibar.

**Dimensional Drawing**

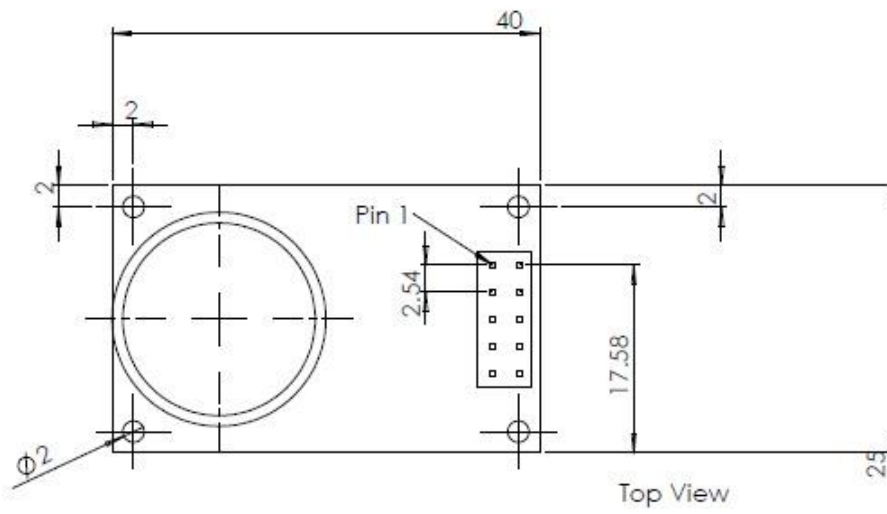
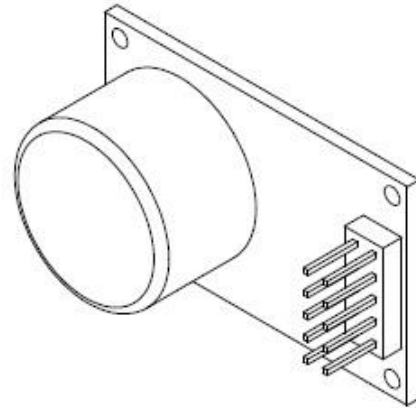
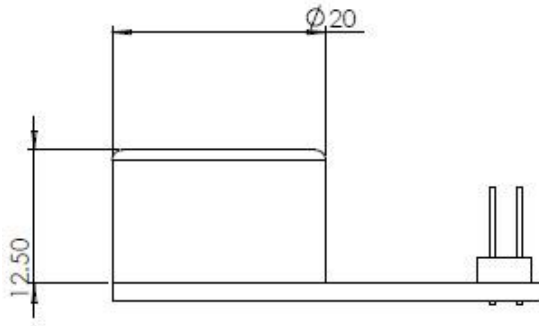

All dimensions  
in millimeters

*Definition of AUX pins for reference.*

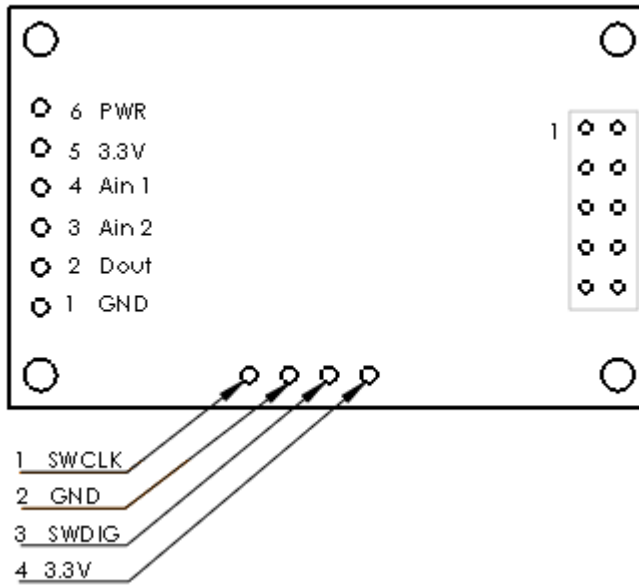



## Chapter 2 : Communications Interface

### General

The MX200 communicates with a host system through a UART interface using either CMOS/TTL Rx and Tx or Differential RS485. The MX200 is a 3V system. The Rx input, however, is fault-tolerant to 5V and will generally interoperate with 3V to 5V systems. The MX200 also has a half-duplex RS485 communication Interface can be operated in either single sensor or multiple sensor mode. Multiple sensor mode permits up to 31 sensors to be multi-dropped on the same differential pair.

### Physical Connections

The MX200 uses a 10 pin (2x5) header with 0.1-inch centers. When viewed from the sensor side with the connector to the left side of the board, Pin 1 is the lower right pin of the header.

### Connector Assignments

Pin	Function	Pin	Function
1	Power and Signal Return	2	PWM Out
3	+3 to +5.5V Power	4	GPIO
5	Rx (Input to Sensor)	6	GPIO
7	Tx (Output from Sensor)	8	RS485 A (Data -)
9	Analog Output (0 - 3V)	10	RS485 B (Data +)

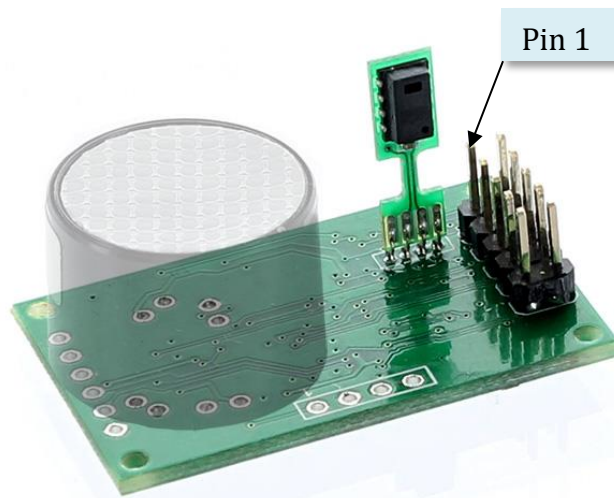

Figure 2-1 MX200 Sensor Controller

### RS485 Input

The RS485 Interface will be used for both transmit and receive. Note that RS485 is two wire half-duplex. The MX200 is normally listening and enables transmit only when transmitting a reply to the host system. The MX has a default address of 5 that can be

changed in parameter 4 of the configuration registers. The host selects a particular sensor using the “!” command

### **PWM Output**

Pin 1 0-100%; 3-volt signal, 1ms time base/ 4096 sub division., suitable for driving PWM to current amplifier for 4-20 mA. Span is controlled by parameter 10, PWM time base is controlled by parameter 14.

### **Analog Output**

Pin 9 is an analog output with a full scale range from 0.00 to 3.00V. The output is derived from a 1ms PWM filtered by a restoration filter consisting of a 130k resistor and 1uF capacitor. The output impedance is approximately 10K. Note that the impedance of the input will reduce the maximum output voltage to approximately  $3.0V * Z / (Z + 10k)$ . For example, with an input impedance of 50K the full-scale output will be  $3.0 * 50k / 60k = 2.5$ Volts. Span is controlled by parameter 11.

### **GPIO Input**

Pin 4 & 6 provide an auxiliary digital input.

### **Link Level Parameters**

The line-level communications parameters are asynchronous 9600 baud, 8 bits, no parity, and a single stop bit. The CMOS 3.3-volt interface, communications is full duplex. For the RS485 interface, communications are half duplex.

### **TTL Protocol**

The host and the controller exchange lines of data. Each line of data to and from the controller is terminated by carriage linefeed (CR LF), i.e. ASCII 0x0d, 0x0a.

The controller always responds to each line. If the line contains a valid command, the controller acts on the command and returns a response. If the line is not recognized as a valid command the controller returns an error response.

### **Modes**

The controller operates in one of two modes, polled or streaming. In polled mode the controller is silent except in response to a command. In streaming mode, the controller reports measurements at intervals of one second (or more) as determined by configuration.

With the CMOS interface, commands may be sent at any time and the controller will continue to stream measurements until the entire command is received. With the RS485 interface, the half-duplex nature of the interface requires that the host is host transmit only in the interval between streamed measurements or responses from the controller.

At power, up the controller enters polled or streaming mode depending on configuration. The mode can be temporarily changed with the K command.

Except during calibration, the controller enters a low power state between measurements. The controller will awaken with the falling edge of any data transmission from the host.

### Commands

Each of the commands supported by the controller is described in the following. Each command consists of a single letter optionally followed by a space and one or two numeric fields separated by a single space. All other letter values not listed are reserved and should not be sent.

The controller always outputs numeric values as 5 decimal digits with leading zeroes if necessary. The controller accepts numeric values with 1 to 5 digits in the range from 0 to 65535.

The controller always responds to a command. The response to a valid and properly formatted command will begin with the command letter except in the case of the “Q” command (which returns the exact line that will be send during streaming). If the command is not valid and properly formatted, the response will be an error code.

### Error Codes:

- 1- ERROR\_UNRECOGNIZED\_COMMAND
- 2- ERROR\_BAD\_FORMAT
- 3- ERROR\_BAD\_VALUE
- 4- ERROR\_BAD\_DATE\_STRING
- 5- ERROR\_RTC\_WRITE
- 6- ERROR\_EEPROM\_READ
- 7- ERROR\_BAD\_PARAMETER
- 8- ERROR\_VALUE\_ALREADY\_SET
- 9- ERROR\_COMMAND\_FAILED
- 10- ERROR\_NOT\_IMPLEMENTED
- 11- ERROR\_NOT\_CONFIGURED

Error responses begin with the letter “E” following by a space and the 5-digit error number. For example, if a command with an invalid command letter is sent the response will be:

```
E 00003<cr><lf>
```

### *B Command – Get Barometric Pressure from on-board Barometer.*

This command gets the barometric pressure. The value is in tenths of millibars in the range from 500 – 1150, i.e. the values returned will be in the range 500 to 11500.

Example Request:

```
B<cr><lf>
```

Example Response:

```
B 10156<cr><lf>
```

This response indicates a barometric pressure of 1015.6 millibars.

### ***b Command – Get Barometric Pressure from UV o2 sensor internal Barometer***

This command gets the barometric pressure. The value is in tenths of millibars in the range from 500 – 1150, i.e. the values returned will be in the range 500 to 11500.

Example Request:

```
b<cr><lf>
```

Example Response:

```
b 10156<cr><lf>
```

This response indicates a barometric pressure of 1015.6 millibars.

### ***G Command – Get Sensor Type***

This command is used to obtain an abbreviation for the type of gas sensor installed.

Example Request:

```
G<cr><lf>
```

Example Response: G 0002 = O2 UV flux 25% G 0001 for CO2

```
G O2 <space><space><cr><lf>
```

Assuming the scale factor from “.” is 1, the above response indicates that the controller is configured for a 25% O2 sensor.

### ***H Command – Get Relative Humidity***

This command is used to get the relative humidity. The value is supplied in tenths of percent relative humidity.

Example Request:

```
H<cr><lf>
```

Example Response:

```
H 00452<cr><lf>
```

#### ***K Command – Set Communications Mode – Not implement.***

This command is used to the communications the communication mode. A value of 1 sets the mode to streaming and a value of 2 sets to the mode to polled. The response is a “K” followed by the new mode. Note: a mode value of 0 is also accepted and behave exactly like Mode 2.

Example Request:

```
K 2<cr><lf>
```

Example Response:

```
K 00001<cr><lf>
```

#### ***P Command – Set Parameter to Value***

This command is used to set the value of a parameter. The command requires the address of the parameter (0 – 31) and the new value.

Example Request:

```
P 4 10<cr><lf>
```

Example Response:

```
P 4 10<cr><lf>
```

#### ***p Command – Get Parameter Value***

This command is used to get the current value for a parameter.

Example Request:

```
p 4<cr><lf>
```

Example Response:

```
p 4<cr><lf>
```

#### ***Q Command – Get Readings -not implemented***

This command is used to get the readings that would be send in streaming mode. The format of the reply depends on current output format as set by the “M” command.

Example Request:

```
Q<cr><lf>
```

Example Response:

```
Z 00004 T 01254 H 00455 B 10149<cr><lf>
```

The above response indicates a gas concentration of 4ppm, a temperature of 25.4 degrees C, a relative humidity of 45.5% and barometric pressure of 1014.9 millibar.

#### ***T Command – Get Temperature (O2 UV Flux sensor)***

This command is used to obtain the current temperature. The response is in tenths of a degree C using an “excess 1000” notation. This always results in a positive value. For example, the reading 01250 corresponds to 25.0C, the reading 01000 corresponds to 0.0C and the reading 00970 corresponds to -3.0C. In other words, just subtract 1000 and the result will be the temperature in signed tenths of degrees C.

Example Request:

```
T<cr><lf>
```

Example Response:

```
T 01275<cr><lf>
```

This response indicates a current temperature of 27.5 Degrees C.

#### ***t Command – Get Temperature (On board RH & T sensor)***

This command is used to obtain the current temperature. The response is in tenths of a degree C using an “excess 1000” notation. This always results in a positive value. For example, the reading 01250 corresponds to 25.0C, the reading 01000 corresponds to 0.0C and the reading 00970 corresponds to -3.0C. In other words, just subtract 1000 and the result will be the temperature in signed tenths of degrees C.

Example Request:

```
t<cr><lf>
```

Example Response:

```
t 01275<cr><lf>
```

This response indicates a current temperature of 27.5 Degrees C.

#### ***U Command – Zero Calibrate***

This command is used to set the zero point for the sensor. Calibration is normally performed using Nitrogen gas at 26C plus or minus 1C as further discussed in Chapter 4.

Example Request:

```
U<cr><lf>
```

Example Response:

```
U 11192<cr><lf>
```

The response to the command is the numeric value corresponding to the zero point. This value can be used with a subsequent “u” command to restore the zero point.

#### ***u Command – Set Zero Calibration Point***

This command is used to manual set the zero point to a value from a previous calibration.

Example Request:

```
u 11192<cr><lf>
```

Example Response:

```
U 11192<cr><lf>
```

#### ***V Command – Get Unfiltered Gas (CO2) Un calibrated (O2) Concentration***

This command is used to obtain the Uncalibrated O2 concentration from UV O2 sensor, or unfiltered (averaged) (i.e. current) for GSS sensor.

Example Request:

```
V<cr><lf>
```

Example Response:

```
V 0003<cr><lf>
```

This example response would be returned for a sensor with a resolution of 1ppm that is seeing a gas concentration of 3ppm.

#### ***W Command – Write Current Parameter Values to Flash***

This command is used to write the current set of parameter values to flash. By design, parameters that are changed are not automatically written to non-volatile memory until a W command is issued or a calibration is performed. When changing any individual parameter, the W command must be executed for the parameter to be retained in flash to be reloaded as default on power up or # restart.

Example Request:

```
W<cr><lf>
```

Example Response:

```
W<cr><lf>
```

#### ***w Command – Restore Parameters to Default***

This command is used to restore all parameters to their default. This will wipe out any calibration that has been performed. The unlock code of “12345” is required to prevent accidentally invoking this command.

The first parameter provides a numeric sensor type which determines the default values.

Example Request:

```
w 1 12345<cr><lf>
```

Example Response:

```
w 1<cr><lf>
```

The w command can be used to set the factory defaults for the type of sensor. The command takes a parameter that indicates the type of the sensor. The types for this are:

Gas type and parameter				
Sensor	MFG	Gas	Range	species, PWM range, multiplier
0	Luminox	O2	25%	2, 25000, 10
1	Luminox	O2	50%	2, 50000, 10



2	GSS	CO2	1%	1, 10000, 1
3	GSS	CO2	5%	1, 5000, 10
4	GSS	CO2	20%	1, 20000, 10
5	GSS	CO2	65%	1, 65000, 10
6	GSS	CO2w	100%	1, 10000, 100

for example:

```
w 0 12345
```

will set the defaults to the Luminox 25% and write them to flash.

Note that the 12345 unlock code is required for this command.

The parameters can also be written from a file on the ec200 tool.

***X Command – Calibrate to specified concentration (SPAN)***

This command is used to calibrate the sensor using a gas of known calibration. The sensor must have been previously zeroed. The calibration gas should be at 25 to 27 degree C. The gas reading must be stable prior to issuing this command.

Example Request:

```
X 500<cr><lf>
```

Example Response:

```
X 16076<cr><lf>
```

Assuming a sensor cell with a 1ppm resolution, this example sets the calibration for 500 ppm. The returned value of 16076 is the filtered ADC value at the calibration point.

***x Command – Reserved for Factory Use***

This command is reserved for factory use.

***Y Command – Report Device Identification***

This command is used to obtain information about the device.

Example Request:

```
Y<cr><lf>
```

Example Response:

```
Y CO2METER MX200 Ver 01 Build 005 S#00077<cr><lf>
```

### ***Z Command – Get Filtered Gas Concentration***

This command is used to obtain the filtered and compensated gas concentration. The 5-digit value returned must be multiplied by the multiplier value to arrive at ppm. For a multiplier of 1, the value will be actual ppm.

Example Request:

```
Z<cr><lf>
```

Example Response:

```
Z 00004<cr><lf>
```

This example response would be returned for a sensor with a resolution of 1ppm that is presently seeing a gas concentration of 4ppm.

### ***# Command – Restart***

Same as power cycle, all 32 parameters registers are reloaded.

Example;

```
# 12345<cr><lf>
```

Response;

```
NO response
```

### ***\$ Command – pass thru character string to GSS***

Example request;

```
$ (any ascii or string of characters) <cr><lf>
```

Response;

```
No Response
```

Example, changing filter term on GSS sensor.

```
A 32<cr><lf>
```

Response;

```
No response.
```

### **% Command – Get Partial Pressure**

This command is used to obtain the partial pressure of the gas. The 5-digit value returned is in base units of tenths of a millibar. For a multiplier of 10, the value will millibars.

Example Request:

```
%<cr><lf>
```

Example Response:

```
% 02020<cr><lf>
```

This example response would be returned for a sensor with a resolution of 1ppm that is presently seeing a partial pressure for the gas of 202.0 millibars.

### **. Command – Get Multiplier**

This command returns the multiplier that should be applied to the gas concentration reading to arrive at ppm. This will generally be 0, 1, 10, or 100 depending on the range of the sensor. Note that 0 is used for a multiplier of 0.1, i.e. 1/10<sup>th</sup> ppm.

Example Request:

```
.<cr><lf>
```

Example Response:

```
. 00001<cr><lf>
```

## **RS 485 Interface Commands**

The RS 485 Interface allows multiple sensors to be controlled from a single host over distances of several hundred feet. All devices as well as the host transmit and receive data over a single wire pair. Note that for distances greater than 10 feet, both ends of the cable should be terminated in the characteristic impedance of the line (typically 100 ohm).

The Protocol used by the RS485 Interface is identical to the TTL interface except for the addition of a “Select” command (!). The select command allows the host to specify which of the multiple devices attached to the line will respond to subsequent commands.

### ***! Command – Select Device***

This command selects the device with the specified address. For device addresses other than 0, the device with the specified address will generate the response. All other devices remain silent. For device address 0, any device on the line will respond and will return its presently configured address. Note that when device address 0 is used – only one device should be present on the line. This feature is intended solely for initial configuration of the device address.

The following example selects device 5.

Example Request:

```
! 5<cr><lf>
```

Example Response:

```
! 00005<cr><lf>
```

Note that the address is provided in the response in the same format as other values, i.e. 0 to 65535 with leading zeros.

All devices will automatically deselect when the ! character is received. This assures that a device will not remain selected due to a communications error. Devices will select only upon receipt of their address or the 0 address.

## Chapter 3 : Configuration

In normal operation, the MX200 automatically detects the sensor type and configures itself accordingly.

### General

The sensor controller configuration is controlled by 32, 16-bit parameter values that are stored in the flash of the microcontroller. These parameters control how the analog front-end device is configured, how values are converted to concentration, and the characteristics of the communication interface.

### Parameter Summary

The following table provides a summary of the 32 parameters and their default settings. All parameters are 16-bit integers (Note that these defaults may not be appropriate for all sensor types).

#	Default Value	Name	Description
0	N/A	Checksum	This is a computed value used to verify integrity
1		Reserved	Output mask not implemented
2		Reserved	
3		Reserved	
4	0	Options Configuration	Configuration Option Word, ADR Modbus, PWM
5	0	Reserved	
6	1	Gas Type	CO2 0001, UV O2 25% 0002
7		Zero	ADC value corresponding to zero at 25C generates at calibration U command.
8		Calibration at Reference gas	ADC value corresponding to ref gas at 25C generated by the X command.
9		Calibration Concentration	Scaled concentration of reference gas ppm stored when X command is executed.
10		Full Scale PWM	Full scale value for PWM; 25000 for UV O2 and 10000 -1% 5000 - 5% 20000 - 20% 10000 -100% CO2. 0= No PWM
11		Full Scale Analog	Full scale value for Analog out: 25000 for UV O2 and 10000 -1% 5000- 5% 20000- 20% 10000- 100% CO2. 0=No Analog out
12	1	Multiplier	Scale Multiplier in ppm sensor dependent. < 2% -1, >2% <32% 10, >32% 100
13		Reserved	
14	4	PWM time base	0-16384 mS for PWM time base 0.25 mS gradation.

15-31		Reserved	
-------	--	----------	--

Example;

Luminox (UV02) is Gas Type 2, PWM full scale 25000 Analog Full scale 25000, multiplier 10 PWM time base 0.

#### **Configuration Option Word (4)**

The configuration option word sets various device options. These include the RS485 device address, the Polling Mode at power up.

Config Options(s)	Default	Bit Value	Description
Streaming	Off	32768	Not implemented
Reserved	Off	16384	
Reserved	Off	8192	
Reserved	Off	4096	
Reserved	Off	2048	
Reserved	Off	1024	-
Reserved	Off	512	-
Reserved	Off	256	-
Reserved	Off	128	-
Reserved	Off	64	-
Reserved	Off	32	-
Device Address	5	0-31	RS485 Device Address 1-31. 0, >31 and no address generates Error 11 when “!” command is executed.

The configuration word is set by adding the bit values for each option.

#### **PWM time base (14)**

Parameter control the base interval for the PWM, the duty cycle is 1:4096.

Change of the parameter requires it to be save using the W command and power cycle or the # restart command

## Chapter 4 : Calibration

**WARNING:** When performing calibration from reference gas always consult the Material Safety Data Sheet for the gas and concentration in use and observe all relevant safety precautions.

### Basic Calibration

Basic Calibration requires first that an accurate zero be set (typically with Nitrogen Gas at 25C +- 1C) and then that a known gas concentration be provided (also at 25C +-1C) and allowed to completely stabilize.

The zero-calibration point is set using the U command. The span reference point is set using the X command. When the X command is executed the microcontroller makes the necessary calculations and stores these in the parameter storage.

## Chapter 5 : Support

The quickest way to obtain technical support is via email. Please send all support inquiries to [support@co2meter.com](mailto:support@co2meter.com).

Please include a clear, concise definition of the problem and any relevant troubleshooting information or steps taken so far, so we can duplicate the problem and quickly respond to your inquiry.

### Warranty

This device comes with a 90 day (warranty period) limited manufacturer's warranty, starting from the date the meter was shipped to the buyer.

During this period, CO2Meter.com warrants our products to be free from defects in materials and workmanship when used for their intended purpose and agrees to fix or replace (at our discretion) any part or product that fails under normal use. To take advantage of this warranty, the product must be returned to CO2Meter.com at your expense. If, after examination, we determine the product is defective, we will repair or replace it at no additional cost to you.

This warranty does not cover any products that have been subjected to misuse, neglect, accident, modifications or repairs by you or by a third party. No employee or reseller of CO2Meter.com's products may alter this warranty verbally or in writing.

### Liability

All liabilities under this agreement shall be limited to the actual cost of the product paid to CO2Meter.com. In no event shall CO2Meter.com be liable for any incidental or consequential damages, lost profits, loss of time, lost sales or loss or damage to data, injury to person or personal property or any other indirect damages as the result of use of our products.

### Returns

If the product fails under normal use during the warranty period, a RMA (Return Material Authorization) number must be obtained from CO2Meter.com. After the item is received CO2Meter.com will repair or replace the item at our discretion.

To obtain a RMA number, call us at or email us at (386) 256-4910 [support@co2meter.com](mailto:support@co2meter.com).

When requesting a RMA please provide reason for return and original order number. If we determine that the product failed because of improper use (water damage, dropping, tampering, electrical damage etc.), or if it is beyond the warranty date, we will inform you of the cost to fix or replace the product.

For more information visit our website: [www.CO2Meter.com/pages/faq](http://www.CO2Meter.com/pages/faq)



## Contact Us

**We are here to help!**

For information or technical support, please contact us.

✉ [support@co2meter.com](mailto:support@co2meter.com)

☎ (386) 256-4910 (Technical Support)

☎ (386) 872-7665 (Sales)

🌐 [www.co2meter.com](http://www.co2meter.com)

Address:

CO2Meter, Inc.

131 Business Center Drive

Ormond Beach, FL 32174

USA