

Diaphragm Pump **PMP-0012**

Flow	800 ml/min
Max. pressure	600 mbar
Max. vacuum	52%

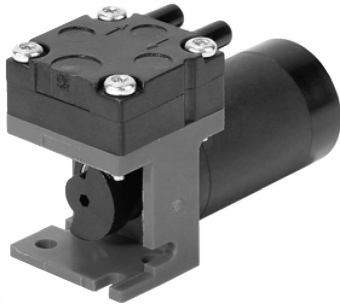

OIL-LESS

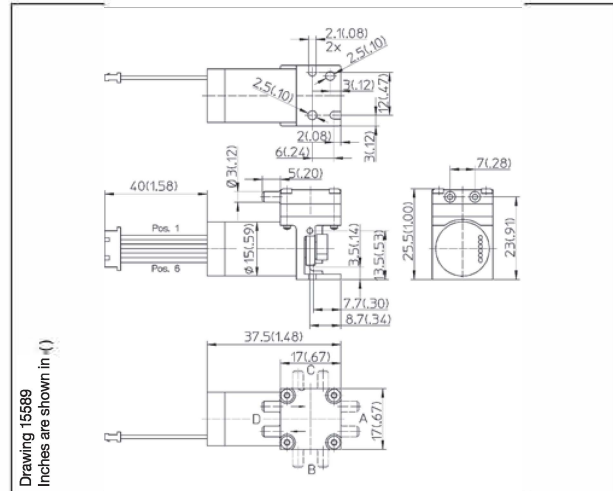

Drawing 15589
Inches are shown in ()

Pneumatic Data

Description	2002VD/0,7/E/BLDC
Part number	20020434
Max. flow	800 ml/min
Max. intermittent duty	550 to 600 mbar
Max. continuous pressure	150 mbar
Max. restart pressure	600 mbar
Max. vacuum	50% to 52%
Max. restart vacuum	52%

Electrical Data

Motor type	Brushless DC
Power consumption	0,8 W
Protection class (Motor)	IP40
Drive electronic	integrated
Bearing type	Ball bearing
Connector type:	Molex 51021-0600 / Terminal 50058-8100

Wiring diagramm:

PIN 1	Vp	red	Electronics supply	5...18VDC
2	Vmot	black	Motor supply	5...18VDC (min. 4VDC higher than input voltage on PIN 4)
3	GND	black	Ground	
4	Vnsoll	black	Speed control	1...4VDC
5	DIR	black	Direction of rotation:	u < 3VDC: CW/ground: CCW
6	FG	black	Signal / 3 impulses per rotation	

General Data

Ambient temperature	10 to 50 °C
Media temperature	10 to 50 °C
Weight	22 g

Wetted Parts

Pump head	Phenol resin
Diaphragm, valves	EPDM

Options

FKM, Silicone

Flow Curves

